

# TECHNICAL MANUAL

## Rolloscope MD and MP Motorized Mammography and Multipurpose Viewers

<b>CONTENTS</b>	<b>SECTION</b>
Safety Information	1
General Information	2
Installation	3
Operation	4
Service	5
Schematics	6
Maintenance and Calibration	7
Maintenance Record	8
Parts List	9

Control Research, Inc. 2006. This document contains or refers to proprietary information that is protected by copyright. All rights are reserved. Copying or other reproduction of this document is prohibited without the prior written permission of Control Research, Inc.

Control Research, Inc.

1775 Winnetka Circle  
Rolling Meadows, IL 60008, USA  
Telephone 847-392-4770

**REVISION RECORD**

Rev.	From Serial No.		To Serial No.		Section and Revision										Date
	MD	MP	MD	MP	1	2	3	4	5	6	7	8	9	10	
1	001	501			1	1	1	1	1	1	1	1	1	1	Sep. 1, 2006

## CONTROL RESEARCH® LIMITED WARRANTY STATEMENT

Control Research, Inc. (CR) warrants this Control Research® Product against defect in material and workmanship for a period of one year from the date of first sale. If CR receives notice of such a defect during the warranty period, CR shall, at its option either repair or replace materials which prove to be defective.

If CR is unable, within a reasonable time, to repair or replace any product to a condition as warranted, Buyer shall be entitled to a refund of the purchase price upon return of the Product to CR at Buyer's expense.

### **LIMITATION OF WARRANTY**

The limited warranty shall not apply to defects in the Product resulting from:

1. Improper or inadequate maintenance by Buyer;
2. Buyer-supplied software for interfacing;
3. Unauthorized modification or misuse;
4. Operation outside of the environmental specifications for the Product;  
or
5. Improper site preparation and maintenance.

THE LIMITED WARRANTY SET FORTH ABOVE IS EXCLUSIVE AND NO OTHER WARRANTY, WHETHER WRITTEN OR ORAL, IS EXPRESSED OR IMPLIED, IS INTENDED. CR SPECIFICALLY DISCLAIMS ANY IMPLIED WARRANTIES OF MERCHANTABILITY AND FITNESS FOR A PARTICULAR PURPOSE. IN NO EVENT SHALL CR BE LIABLE UNDER THIS LIMITED WARRANTY FOR ANY CONSEQUENTIAL DAMAGES INCURRED BY ANY PERSON BY REASON OF USE OR DEFECT IN THE PRODUCT NOR SHALL CR BE LIABLE HEREUNDER FOR MORE THAN THE PURCHASE PRICE PAID FOR THE PRODUCT.

Control Research® is a registered trademark of CONTROL RESEARCH, INC.

September 2006

**SECTION 1**  
**SAFETY INFORMATION**

<b>CONTENTS</b>	<b>PAGE</b>
1.1 User Responsibility .....	1.1
1.2 Safety Conventions .....	1.1
1.3 General Safety Information .....	1.2

## 1.1 User Responsibility

This product will perform in conformance with the described specifications when it has been installed, operated and maintained in accordance with the procedures described herein.

Periodic inspection of the Rolloscope will insure that it continues to perform within the described limits. If any part is found to be worn, broken, or damaged in any way, immediately make arrangements to have the problem corrected.

The Rolloscope should be repaired only by qualified personnel using specified procedures.

Any alteration to the system, not in accordance with the procedures set forth by Control Research places sole responsibility on the user for any malfunction resulting from faulty maintenance, improper repair, damage, or alteration.

This system conforms to all federal regulations governing Film Viewing Equipment. Check with your local regulatory agency for any other requirements before operating the Rolloscope.

The Rolloscope should only be operated by AUTHORIZED PERSONNEL. The system should be turned off when not in use.

## 1.2 Safety Conventions

Specific notations are used in this manual to call attention to conditions that could potentially result in personnel injury, damage to equipment, or require special attention.

### WARNING

A **WARNING** notation is used to describe an operating or maintenance procedure, practice, or condition which if not strictly observed, could result in injury or loss of life.

### CAUTION

A **CAUTION** notation is used to describe an operating or maintenance procedure, practice, or condition which if not strictly observed could result in damage or destruction of the equipment.

### NOTE:

A **NOTE** is used to describe a general rule for a procedure or an exception that requires the attention of the operator.

### 1.3 General Safety Information

#### WARNING

#### TO BE SERVICED BY QUALIFIED PERSONNEL ONLY

During some test and calibration procedures, it is necessary to operate the Rolloscope with the covers off. Exercise extreme caution, staying clear of **moving chains and live electrical circuits**.

#### DO NOT SERVICE OR ADJUST ALONE

Do not attempt internal service or adjustment unless another person, capable of rendering first aid and resuscitation, is present.

#### GROUND THE SYSTEM

To minimize shock hazard, the system chassis and cabinet must be connected to an electrical ground. The Rolloscope is equipped with a three-conductor Hospital Grade AC power connector. The power connector must be plugged into an approved Hospital Grade three-contact electrical outlet. Figure 1-1 shows a US electrical outlet.

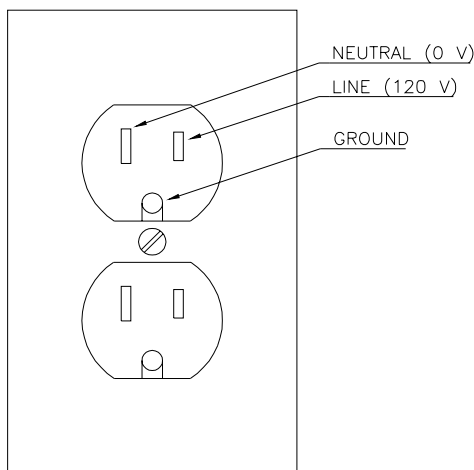

Figure 1-1. Outlet used in US and Canada



#### PROTECTING AGAINST ELECTROSTATIC DISCHARGE

Static electricity can harm delicate components inside the Rolloscope. To prevent static damage, discharge static electricity from your body before you touch any of the components on the PC boards. You can do so by touching an unpainted metal surface of the Rolloscope chassis. When working or handling PC boards, use wrist straps.

#### AVOID ENVIRONMENTAL EXTREMES

The Rolloscope is designed to be operated and stored in controlled environments only. This system should not be exposed to extremes in temperature or humidity.

#### DO NOT OPERATE IN AN EXPLOSIVE ATMOSPHERE

Do not operate the system in the presence of flammable gases, fumes, or suspended dust particles. Fire or explosions could result because of ignition from electrical arcing.

#### DO NOT PULL ON POWER CORD

When disconnecting power plug from wall outlet, **DO NOT PULL ON POWER CORD.**

**SECTION 2**  
**GENERAL INFORMATION**

<b>CONTENTS</b>	<b>PAGE</b>
2.1 Introduction .....	2.1
2.2 Specifications .....	2.2
2.3 Decals and Labels .....	2.4
2.4 Glossary of Symbols .....	2.4

## 2.1 Introduction

The Rolloscope models MD and MP are motorized film viewers, especially made for viewing mammographic X-ray films, but they can also be used for viewing full size films.

This manual covers both models MD and MP shown in Figure 2-1, however, most of the illustrations are based on the model MD. The MP model is wider and can hold more films than the MD model, otherwise, the two models are identical. Rolloscope MD and MP have the following features:

- High capacity, up to 1616 (1212 for MD) 18 x 24 cm films.
- Light output range 350 - 12,000 nit (350 - 10,000 for MD).
- Automatic masking for each preset frame.
- Roam function with single joystick.
- Frame selector for single step, scrolling or frame number.
- Connects to a standard 100-120 or 200-240 Volts outlet.
- Moves easily on 3" swivel casters.
- Fits through most standard doors.
- Optional foot switch for single step or scrolling.

For an overview of the operating principle of the Rolloscope, see the first part of the Operation section of this manual.

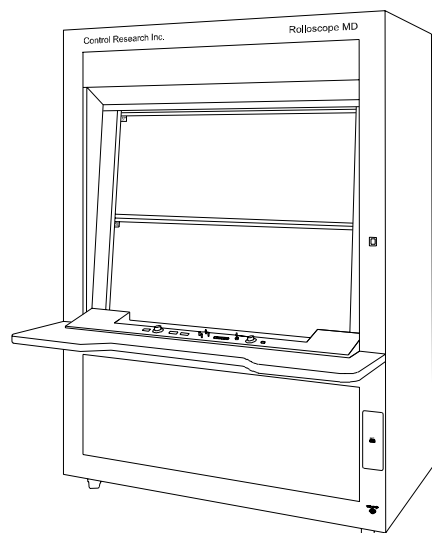

Model MD  
Without Monitors

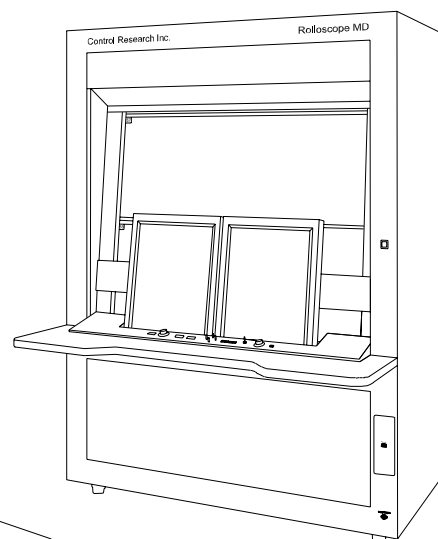

Model MD  
With Monitors

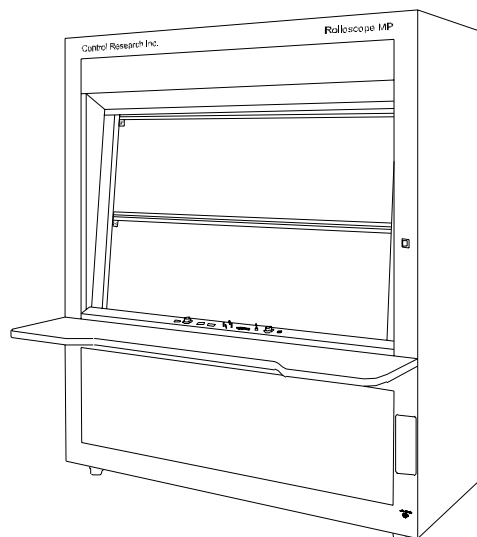

Model MP

Figure 2-1. Rolloscope MD and MP

## 2.2 Specifications

### Type and Model Numbers

Type	Model Number
Rolloscope MD, 100 - 120 VAC 50/60 Hz or Rolloscope MD, 200 - 240 VAC 50/60 Hz	161-001
Rolloscope MP, 100 - 120 VAC 50/60 Hz or Rolloscope MP, 200 - 240 VAC 50/60 Hz	171 -001

### General

	Model MD	Model MP
Viewing Area	42.5" x 36.5" (1079 x 927 mm)	54.5" x 36.5" (1384 x 927 mm)
Maximum Viewing Capacity		
18 x 24 cm film	1,212 (6 over 6)	1,616 (8 over 8)
24 x 30 cm film	404 (4 across)	606 (6 across)
14" x 17" film	303 (3 across)	404 (4 across)
Luminance Level	350 - 10,000 nit (cd/m <sup>2</sup> )	350 - 12,000 nit (cd/m <sup>2</sup> )
Color Temperature	7,000 deg. Kelvin	7,000 deg. Kelvin
Lamp Type	48" Fluorescent Daylight, 36 W	60" Fluorescent Daylight, 58 W
Power Required	100 - 120 VAC, 15 A, 50/60 Hz or 200 - 240 VAC, 10 A, 50/60 Hz	100 - 120 VAC, 15 A, 50/60 Hz or 200 - 240 VAC, 10 A, 50/60 Hz
Power Consumption	6.3 Amps Maximum @ 120 VAC 3.4 Amps Maximum @ 220 VAC	9.5 Amps Maximum @ 120 VAC 5.2 Amps Maximum @ 220 VAC
Heat Output	Max: 2,700 BTU/hr	Max: 3,900 BTU/hr
Weight	1,130 lbs. (512 kg)	1,300 lbs. (589 kg)

### Environmental

	Operating	Storage
Temperature	50 - 85 deg. F (10 - 30 deg. C)	-4 - 140 deg. F (-20 - 60 deg. C)
Humidity	30 - 80% (no condensation)	20 - 90% (no condensation)



### 2.3 Decals and Labels

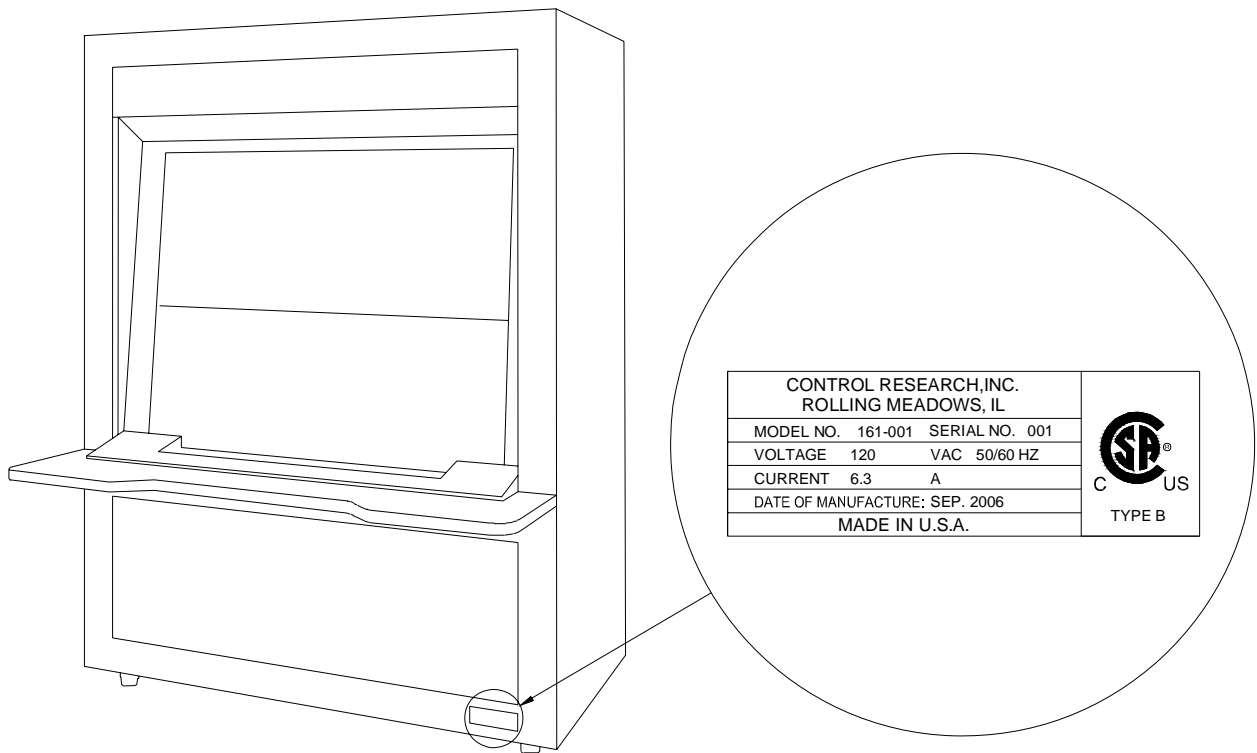



Figure 2-3. ID Label

### 2.4 Glossary of Symbols (Le glossaire de Symboles)

- I Power On (Le Pouvoir Sur)
- O Power Off (Eteindre Pouvoir)
-  Ground Terminal (Le circuit de liaison a la terre)

**SECTION 3**  
**INSTALLATION**

<b>CONTENTS</b>	<b>PAGE</b>
3.1 Initial Inspection .....	3.1
3.2 Unpacking .....	3.1
3.3 Installing the Table .....	3.2
3.4 Connecting Optional Foot Switch .....	3.3
3.5 Line Power Connection .....	3.4
3.6 Functional Checks .....	3.5

### 3.1 Initial Inspection

Each Rolloscope is carefully inspected, both mechanically and electrically before shipment. It should be free from damage and in perfect operating order upon receipt.

To confirm this, the system should be inspected for physical damage incurred in transit. If damage is found, contact the carrier and the distributor for instructions. Retain the packing material.

### 3.2 Unpacking

Most of the domestic shipments are made by Van Lines. The Rolloscope in this case does not need to be crated, but is wrapped in plastic for protection.

Carefully unpack the Rolloscope and verify that all standard and optional items according to Figure 3-2 are present.

The unpacking should take place only after a **dust-free location**, where the Rolloscope will be used, has been reserved and prepared.

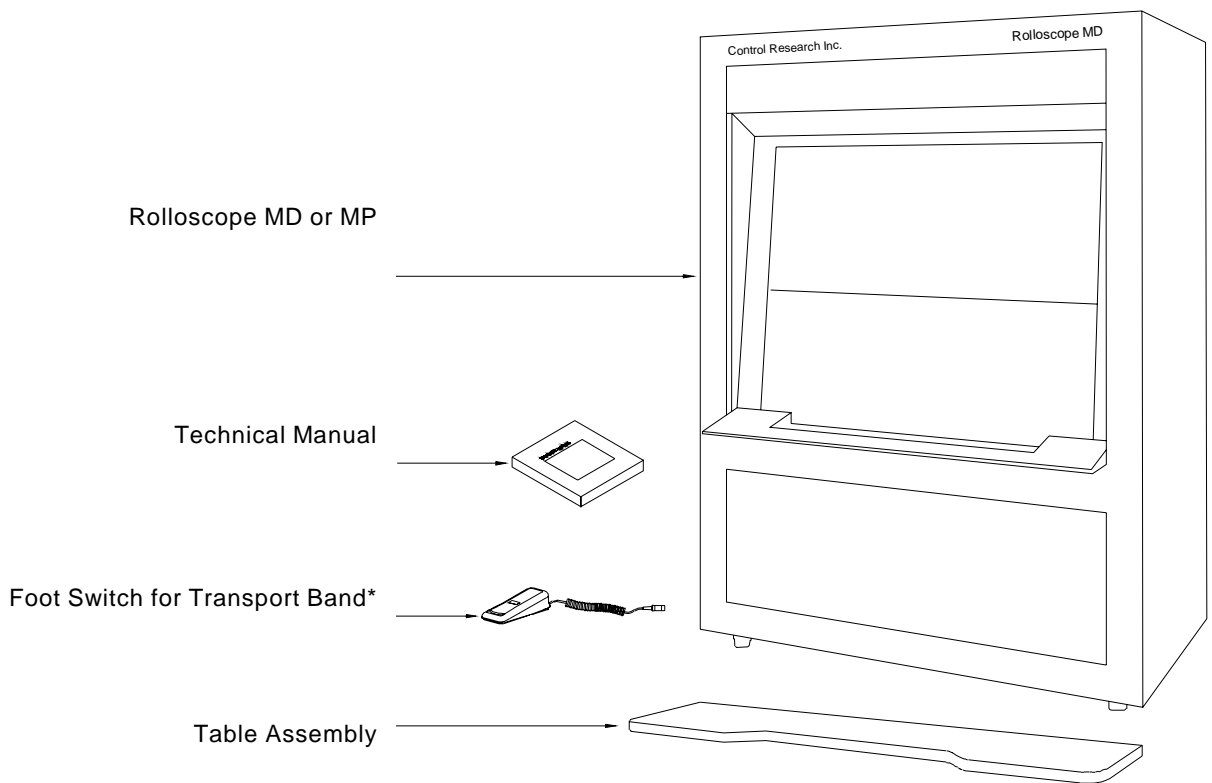

Figure 3-2. Items Shipped with Rolloscope

\* Note: Optional Item, only included if ordered.

### 3.3 Installing the Table

The Table (2 in Figure 3-3) is held by four bolts (3 in Figure 3-3) to the Rolloscope. To install the table, proceed as follows:

- a. Use a ½ inch wrench and loosen the four bolts (3) about 1/4 inch.
- b. Install the table by placing the slots in the table brackets (1) over the heads of the bolts.
- c. Make certain that the table is properly seated with the top of the slots resting on the bolts, then tighten the bolts.

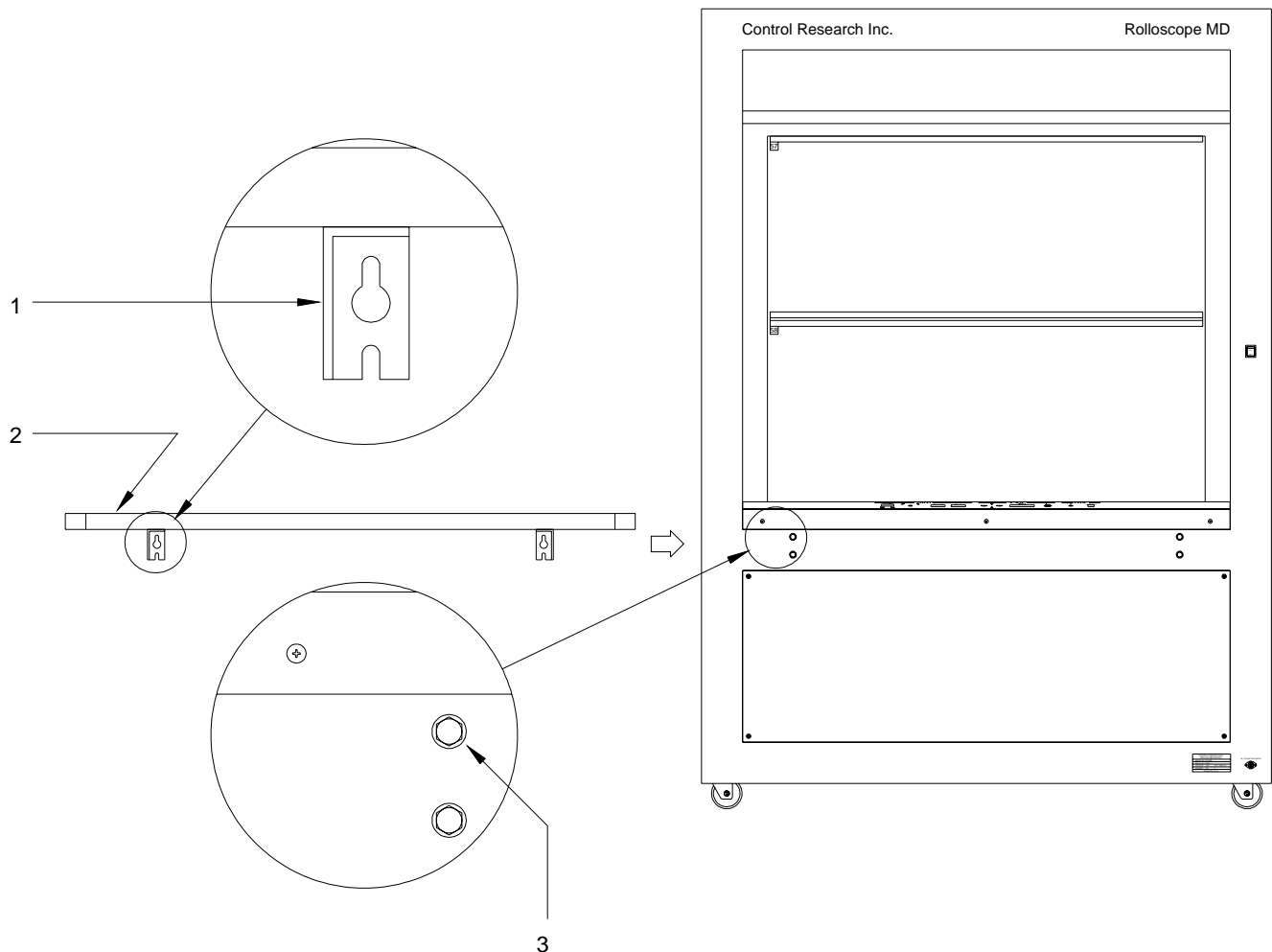

Figure 3-3. Installing the Table

### 3.4 Connecting Optional Foot Switch

If an optional foot switch has been ordered, connect it as shown in Figure 3-4.

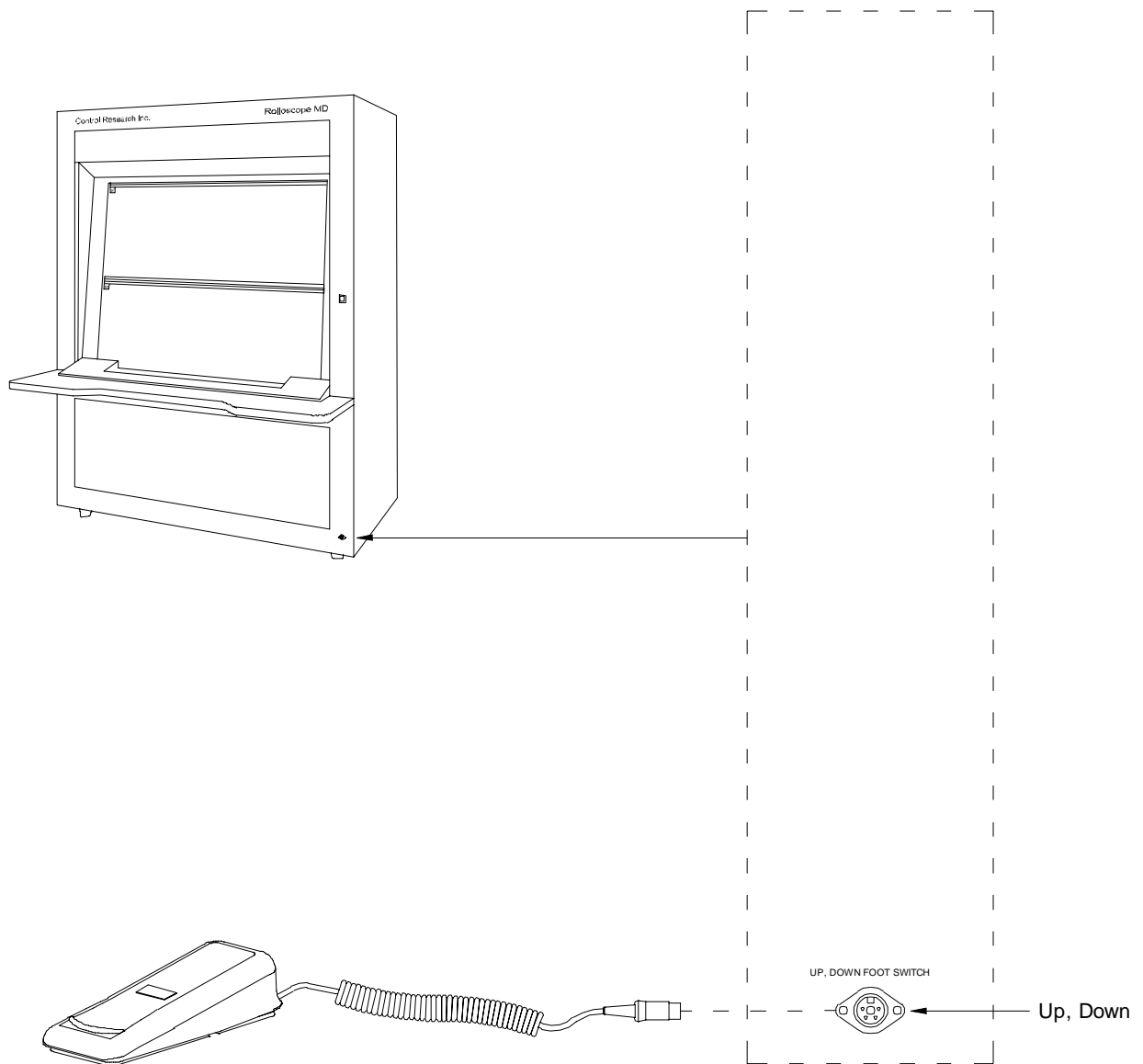

Figure 3-4. Connecting Optional Foot Switch

### 3.5 Line Power Connection

- a. Measure the voltage at the outlet where the Rolloscope will be connected. Make certain that the line power matches the power specified on the Rolloscope ID Label found at the front lower right corner.

**WARNING**

For protection of the operating personnel the power source has to be an **approved Hospital Grade outlet with safety ground**.

**WARNING**

**Disconnect power before servicing.**

- b. If the line power is different from what is specified on the ID Label, different taps are available on transformer T1, located behind the lower front cover. Remove the lower front cover by following the instructions in section 5.2.2 and make connections according to Figure 3-5.

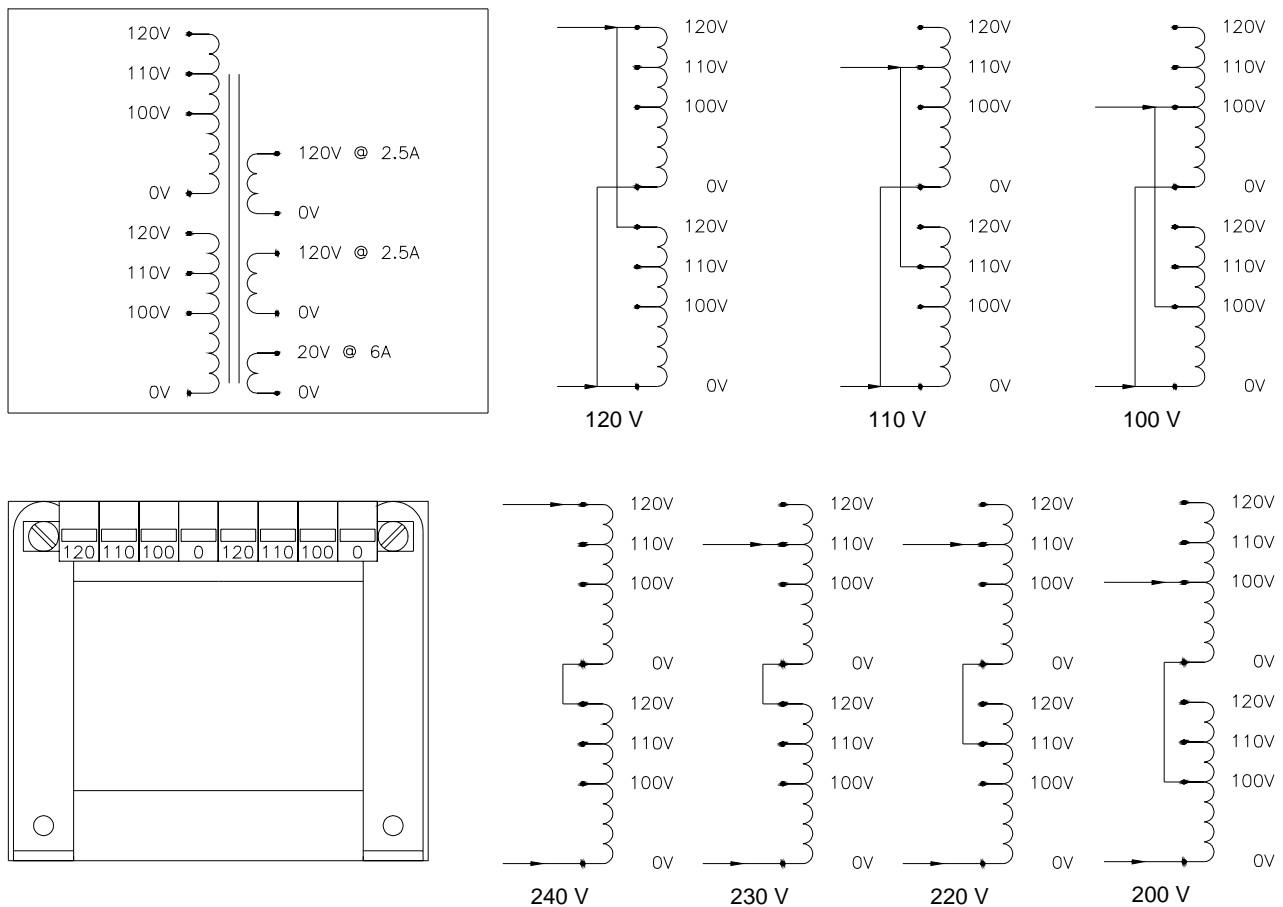

Figure 3-5. T1 Transformer Connection for Different Line Voltages

## 3.6 Functional Checks

Providing that previous steps have been completed, connect the Rolloscope to the power outlet then check and verify that the Rolloscope is functioning properly. See the Operation section of this manual and proceed as follows:

- a. Turn the Rolloscope on and verify that the green light in the Main Switch comes on.
- b. Drive the transport band from frame #1 to frame #85. Check for smooth operation and that all film holding strings are present.
- c. Select several different frames and verify that the transport band stops correctly.
- d. While the transport band moves from one selected number to another, press the STOP button and make certain that the transport band stops at the next frame.
- e. Press NEXT UP and NEXT DOWN switches and verify the function.
- f. Press LAMPS ON/OFF switch and verify that the lights in the light box turn on.
- g. Turn the INTENSITY knob and verify that the light intensity adjusts properly.
- h. Operate one shutter at a time and verify that it opens fully and closes down to about 3 inches (76 mm). It is possible that the shutters during shipment have moved from their calibrated positions and needs re-setting. In this case, go to "Adjusting Shutter System".
- i. Store a different field in each of the PRESETS 1, 2, 3 and 4 and confirm that each of the fields can be recalled at any time and in any frame.
- j. Check that AUTO MODE ON and AUTO MODE OFF are working correctly then leave it in AUTO MODE ON. In AUTO MODE ON, the shutter position in each frame number is automatically memorized. For a description of AUTO MODE, see "Shutter Control" in the Operation section of this manual.
- k. Set a small field and test the ROAM control, horizontally, vertically and diagonally.
- l. Check functions of optional foot switch (if included in delivery).

### Adjusting Shutter System

If the shutters, during the previous test, do not open or close correctly, it will be necessary to do a reset procedure as follows:

- a. Press and hold Preset Switches 1 and 4 (see Figure 4-3-5) until the light in both switches flash once. This loads an artificial number into the electronic positioning system, enabling shutter movement in both directions.
- b. Move the shutters out with the individual controls but make certain to release the shutter control switch as soon as the shutter reach its fully open position.
- c. Repeat this procedure if necessary until all four shutters are returned to their fully open position. Driving the shutters against the stops will produce a rattling sound (cogging). Note that this will not cause any damage if done briefly.
- d. Press and hold Preset Switches 2 and 3 until the light in both switches flashes once. This sets the electronic positioning counters to zero. The shutters are now calibrated.

**SECTION 4**  
**OPERATION**

<b>CONTENTS</b>	<b>PAGE</b>
4.1 Operating Principle .....	4.1
4.2 Locating the Controls .....	4.3
4.3 Control Panel .....	4.5
4.4 Loading and Unloading Film .....	4.8

## 4.1 Operating Principle

The operating principle for the Rolloscope is illustrated in Figure 4-1. The following is a description of the components:

### 1. Lower Transport Band Take-Up Reel

When the first frame is selected for viewing, the rest of the film transport band with all films loaded are wound up on this take-up reel.

### 2. Upper Transport Band Take-Up Reel

For each higher frame selected, the film transport band moves up and winds onto the upper take-up reel. When viewing the last frame, all previous frames are now stored on this take-up reel.

### 3. Light Box

Multiple fluorescent lamps, providing a high intensity of light, are placed inside the light box.

### 4. Elastic Bands

When the films are moved out of the viewing area, elastic bands are placed in front of them. This will protect and hold the films in place as they are moving into the take-up reels.

### 5. Shutter

After the films have been loaded to the frame in the viewing area, the shutters are set to cover the area not occupied by the films. There are four independent shutters, two vertical (upper and lower) and two horizontal. Only the vertical shutters are shown in Figure 4-1.

### 6. Diffuser

The acrylic diffuser in the front part of the light box makes the light distribution even across the viewing area.

### 7. Transport Band

The transport band with film holding clips, see enlargement in Figure 4-1, is used for holding and transporting the films to the viewing area and onto the take-up reels.

### 8. Shutter Shield

The shutter shield is a clear acrylic sheet placed between the shutter and the transport band. It protects the shutter and also provides a solid support when loading the films to the transport band.

**4.1 Operating Principle, continued**

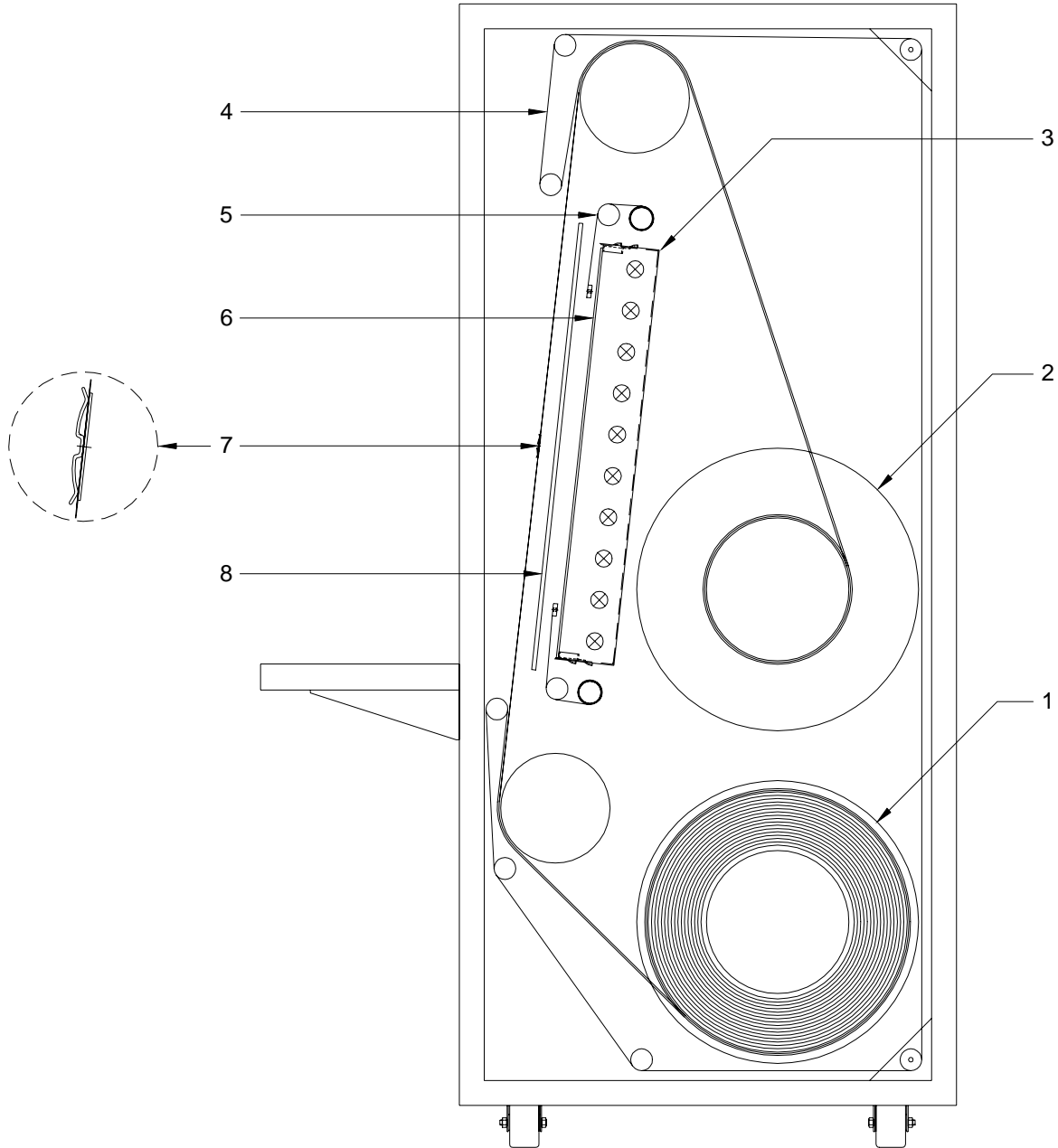

Figure 4-1. Operating Principle

## 4.2 Locating the Controls

### Main Switch

The Main Switch, located on the front right side as shown in Figure 4-2-1, turns the power on and off. It is suggested that when the Rolloscope is not in use, the power is turned off.

**CAUTION**

Before the Rolloscope is turned on for the first time, make certain that it is connected to a properly grounded outlet and that the input transformer is set for the correct voltage.

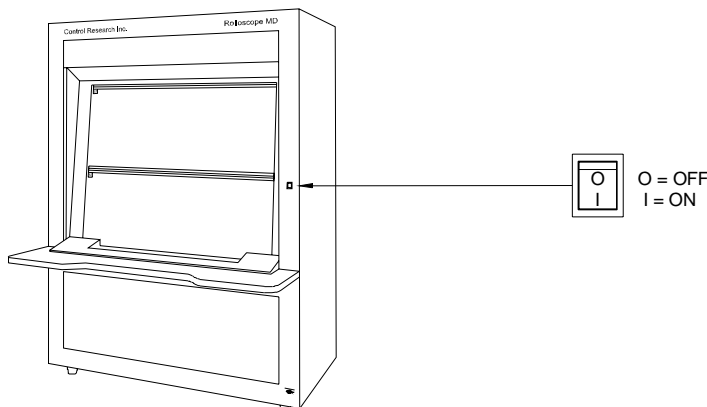

Figure 4-2-1. Location of Main Switch

### Control Panel

The Control Panel, shown in Figure 4-2-2, is located at the lower edge of the film viewing area. The controls are divided into three sectors, Lamp Control,

Shutter Control and Frame Selector. The Control Panel will be described in detail later in this section of the manual.

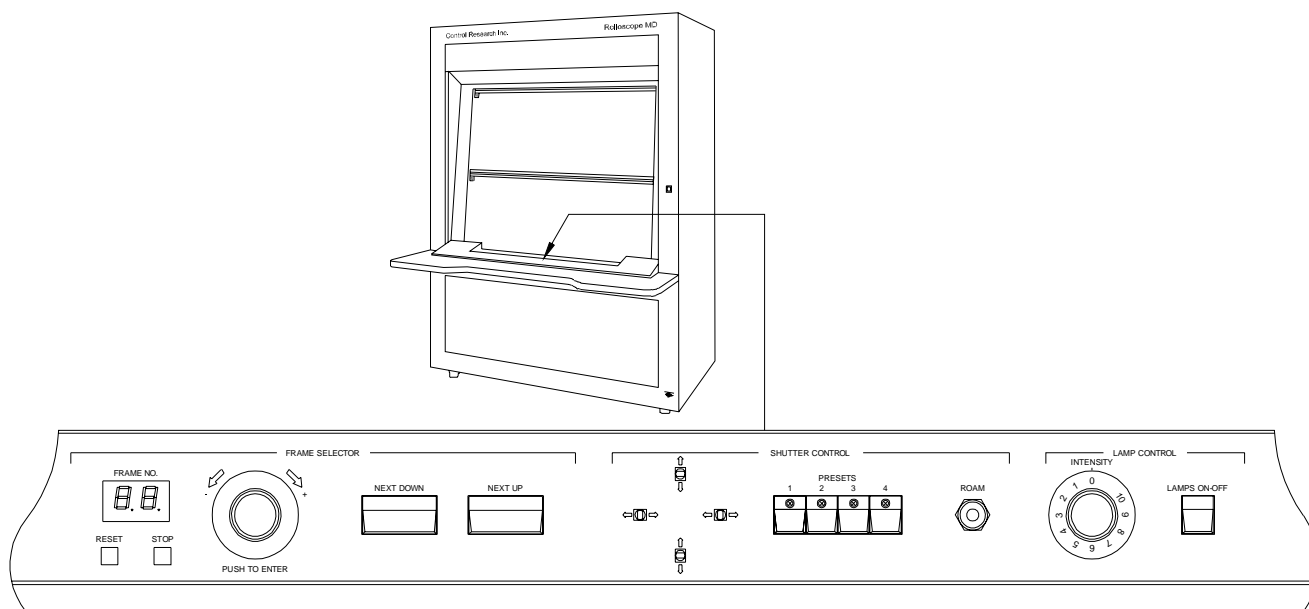

Figure 4-2-2. Control Panel

## 4.2 Locating the Controls, continued

### Auxiliary Receptacles, see Figure 4-2-3

#### 1. RS232 Computer Connection

The RS232 connector is standard on Rolloscope MD and optional on Rolloscope MP. It allows the Rolloscope to be controlled by, or communicate with, an external computer. It can be used to synchronize the films on the Rolloscope with digital images on another system such as a digital work station. Any computer with a serial port, or USB to serial converter, can be used (by selecting Hyper Terminal in Windows) to make the Rolloscope go to a selected frame. Typing in F25 makes it go to frame 25, N1 means Next up, N0 next down, etc. The Rolloscope also sends out communication each time it moves, to let the digital system know where it is.

#### 2. Up-Down Foot Switch Receptacle

With the optional up-down foot switch connected to this receptacle, the foot switch will move the transport band one frame when activated momentarily or continuously scrolling when held down.

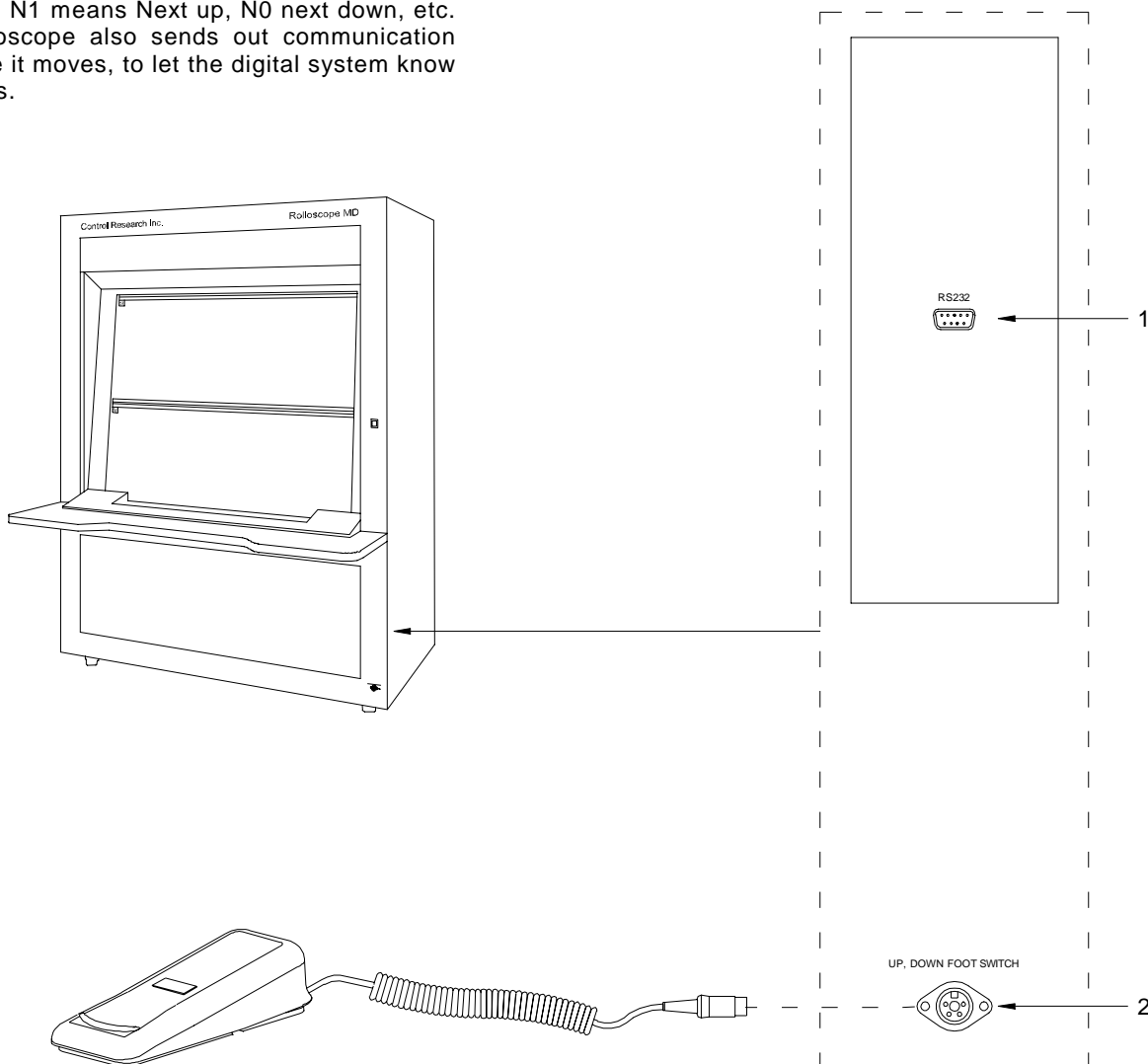

Figure 4-2-3. Auxiliary Receptacles

### 4.3 Control Panel

The Control Panel, as shown in Figure 4-2-2, is divided into three sections, Lamp Control, Shutter Control and Frame Selector.

#### LAMP CONTROL, See Figure 4-3-1

##### 1. LAMPS ON-OFF

This switch will turn the fluorescent lamps in the light box on and off.

**Note:** During film transport band movement, the lights will automatically dim to minimum intensity.

##### 2. INTENSITY

By turning this knob, the light intensity can be adjusted from a minimum (0) to a maximum (10).

**Note:** In order to prolong the service life of the fluorescent lamps, and to conserve energy, the lamps, if no controls are manipulated, are automatically switched off after 20 minutes. Pressing the LAMPS ON-OFF switch, will turn the lamps back on.

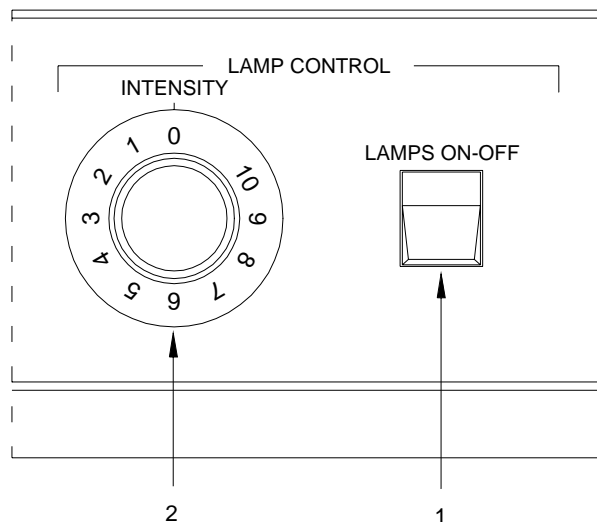

Figure 4-3-1. Lamp Control

#### FRAME SELECTOR

The Frame Selector (and the foot switch) controls the movement of the film transport band. Depending on the size of the films being viewed, one of two modes can be selected.

##### a. Normal Mode

As shown in Figure 4-3-2 the Film Holder is in the middle of the viewing area. To switch between Normal Mode and High Film Clip Mode, press and hold the Stop button (item 4 in Figure 4-3-4) for more than 2.5 seconds.

##### b. High Film Clip Mode

As shown in Figure 4-3-3 one of the Film Holders is in the middle of the upper half viewing area and the next Film Holder is in the middle of the lower half viewing area. The High Film Clip mode is useful mainly with the Rolloscope MD, where it can provide two rows of 18 x 24 cm films above the digital monitors. To switch between High Film Clip Mode and Normal Mode, press and hold the Stop button (item 4 in Figure 4-3-4) for more than 2.5 seconds.



Figure 4-3-2. Normal Mode

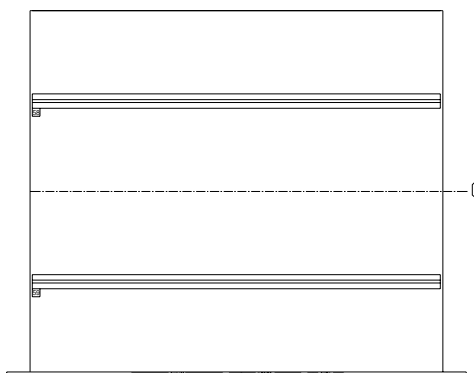

Figure 4-3-3. High Film Clip Mode

### 4.3 Control Panel, continued

#### FRAME SELECTOR, continued

The controls on the frame selector are shown in Figure 4-3-4.

**1. NEXT UP**

When pressing this switch momentarily, the transport band moves up to the next frame. If the switch is held down, the transport band will scroll upwards until the switch is released or the band comes to its end position.

**2. NEXT DOWN**

When pressing this switch momentarily, the transport band moves down to the next frame. If the switch is held down, the transport band will scroll downwards until the switch is released or the band comes to its end position.

**3. FRAME NUMBER CONTROL**

To move to a specific frame number, select the desired frame by turning this control until the correct number is shown on the FRAME NO. display (5). Push the control and the transport band starts moving towards the frame selected. The FRAME NO. display (5) will be flashing until the correct frame has been reached.

**4. STOP**

Pressing the STOP during transport band movement, will cancel the selected frame and make the band stop at next available frame. Holding the STOP button down for more than 2.5 seconds will shift between Normal Mode and High Film Clip Mode.

**5. FRAME NO.**

The FRAME NO. display shows the frame number in the viewing area or the frame number selected. When a new frame number has been selected, the FRAME NO. display is flashing until the transport band has moved to the new location.

**6. RESET**

If the number on the FRAME NO. display does not correspond to the frame number in the viewing area, the frame selector can be reset as follows:

- Dial in the number of the frame presently in the viewing area.
- Press and hold the RESET button, until the display stops flashing.

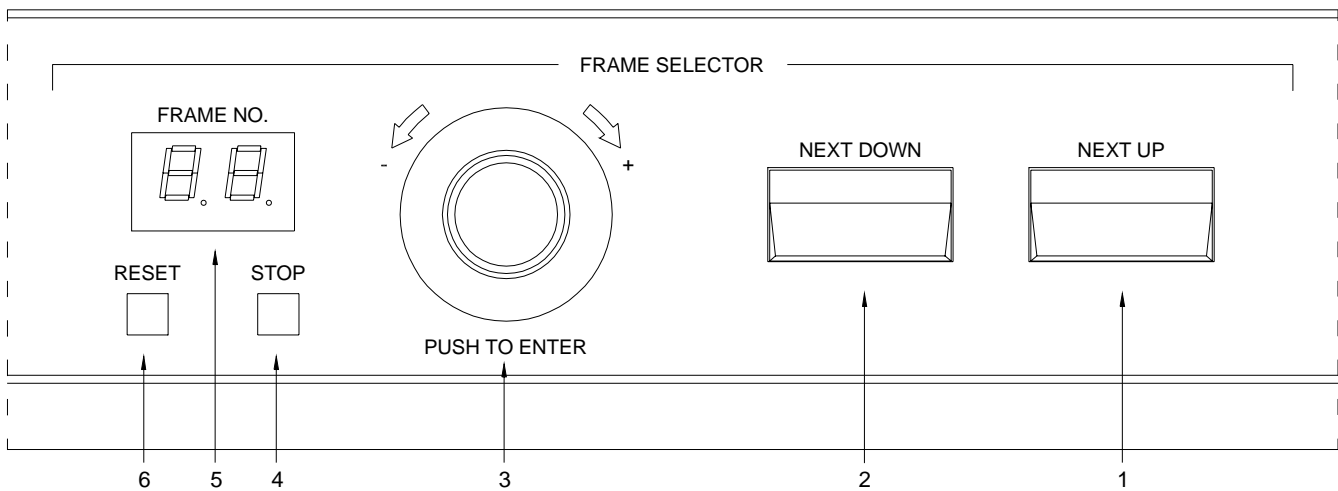

Figure 4-3-4. Frame Selector

### 4.3 Control Panel, continued

#### SHUTTER CONTROL

The shutter control is shown in Figure 4-3-5.

##### 1. SHUTTER CONTROL SWITCHES

Each of the four independent shutters (two vertical and two horizontal) are controlled by the four toggle switches. The shutters will move in the direction of the arrows. The viewing area can be masked to any size down to 2.5" x 3".

##### 2. PRESETS

Up to four frequently used masked fields can be stored.

###### a. Storing a masked field.

First set the field using the Shutter Control Switches. Then press and hold one of the preset switches 1, 2, 3 or 4 until the lamp on this switch is momentarily turning off. The size is now set.

###### b. Applying a stored field.

To apply the stored field, press the appropriate preset switch momentarily.

##### 3. ROAM

The ROAM Control is a joystick which moves the masked area around (roams) the viewing area, without changing its size or shape.

##### AUTO MODE ON (PRESET switches 2+4)

In this mode the last shutter setting for each frame is remembered and will automatically be set when returning to that frame. The AUTO MODE is turned on by holding PRESETS switches 2 and 4 down at the same time until the light in both switches momentarily flash. This is the preferred mode of operation. The shutters are set when loading the films and will not have to be manipulated again when reading the films.

##### AUTO MODE OFF (PRESETS switches 2+4)

The AUTO MODE is turned off by holding PRESETS switches 2 and 4 down at the same time until the light in both switches momentarily flash.

##### SPOT MODE ON (Preset switches 3+4)

Pressing PRESET switches 3 and 4 down at the same time will cause the shutters to go to the smallest size at the center of the current window. This will light all of the PRESET LED's until turned off. In this mode the roam function is still active.

##### SPOT MODE OFF (PRESETS switches 3+4)

Pressing PRESETS switches 3 and 4 down at the same time will return the shutters to the previous position and turn the switch LED's off.

##### FULL SCREEN PRESETS (PRESETS switches 1+2)

Pressing PRESETS switches 1 and 2 at the same time will cause the shutters to move to the full open positions.

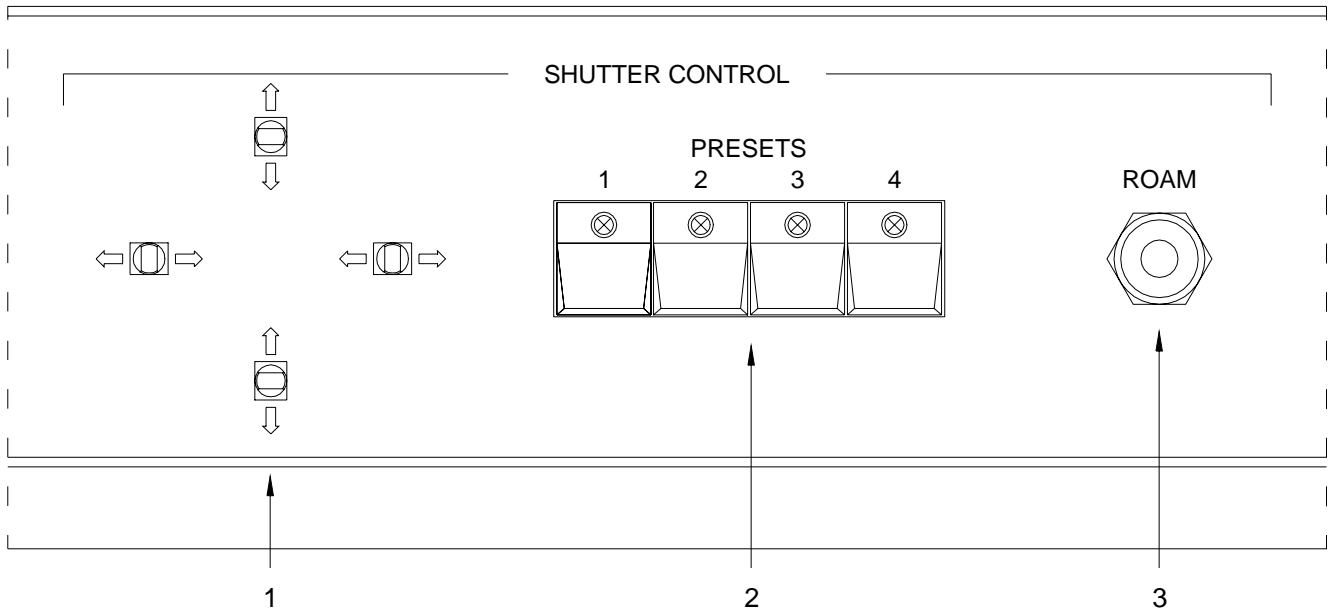

Figure 4-3-5. Shutter Control

## 4.4 Loading and Unloading Film

### 1. Loading Film

Larger and smaller size films can be loaded by inserting the upper edge of the film under the lower edge of the film holder.

Smaller size films can also be loaded by inserting the lower edge of the film under the upper edge of the film holder.

Films are best inserted by starting with a corner. A corner is first secured under the film holder and the remainder of the edge is inserted by rotating the film around the corner pivot point. This is illustrated in Figure 4-3-6.

Smaller size films secured at the lower edge and full size films secured at the upper edge should be tucked under the holding string for additional security.

**Important Note:** Films must not be placed outside the right or left edges of the film holder. Doing so, may cause them to interfere with the photo sensors operating along the edges of the transport band.

**Step 1:** Insert film corner under clip.

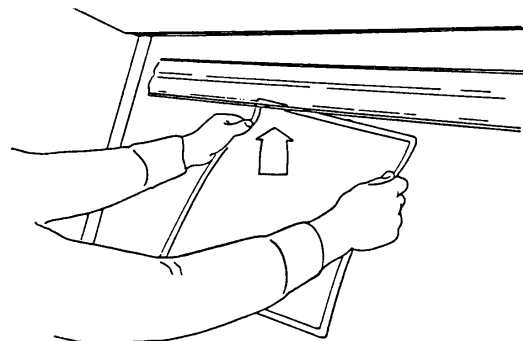

**Step 2:** Rotate film around captive corner while pushing up.

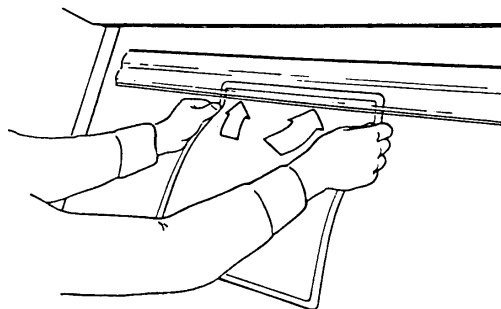

Figure 4-3-6. Film Loading

### 2. Unloading Film

Films can be removed by simply pulling them out from the film holder.

## SECTION 5

### SERVICE

<b>CONTENTS</b>	<b>PAGE</b>
5.1 Introduction .....	5.1
5.2 Preparing for Service .....	5.1
5.2.1 Positioning Transport Band for Service .....	5.2
5.2.2 Removing Covers .....	5.5
5.3 Locating PC Boards .....	5.6
5.4 Fuse Replacement .....	5.7
5.5 Replacing Shutter Shield .....	5.8
5.6 Replacing Diffuser .....	5.9
5.7 Replacing Fluorescent Lamps .....	5.10
5.8 Replacing PC Boards .....	5.11
5.9 Servicing Control Panel .....	5.11
5.9.1 Preparation for Servicing Control Panel .....	5.12
5.9.2 Replacing Rotary Encoder .....	5.14
5.9.3 Replacing Shutter Joy Stick .....	5.15
5.9.4 Replacing Frame Selector Board .....	5.15
5.9.5 Replacing Shutter Switch Board .....	5.15
5.10 Replacing Batteries .....	5.16
5.11 Replacing Anti-Static Brushes .....	5.17
5.12 Replacing Ballasts .....	5.18
5.13 Servicing Transport Band Drive .....	5.19
5.13.1 Replacing PC Boards for Transport Band Drive .....	5.20
5.13.2 Replacing DC Motor .....	5.21
5.13.3 Replacing Magnetic Sensor .....	5.22
5.13.4 Replacing Photo Sensor .....	5.23
5.13.5 Replacing Gear Tooth Sensor .....	5.24
5.13.6 Replacing Frequency/Voltage Converter .....	5.24
5.14 Servicing Shutter Drive .....	5.25
5.14.1 Replacing PC Boards for Shutter Drive .....	5.27
5.14.2 Replacing Step Motors .....	5.28

## 5.1 Introduction

The Rolloscope is designed to require minimum service and maintenance. Major mechanical components of the Rolloscope are designed for long life expectancy. In addition, the electronic controls incorporate integrated circuits which are very reliable. Service is therefore mostly limited to replacement of such items as fluorescent lamps and items subject to wear and tear.

Before a component is replaced, always make certain that the malfunction of it is not caused by improper calibration. For calibration procedures, see the maintenance section of this manual. For available parts and their location in the unit, see the parts section of this manual.

### WARNING

Read and follow the steps in the Safety Information section of this manual.

### WARNING

Disconnect the power cord before removing any of the covers. Should it be necessary to operate the unit with the covers off, exercise extreme caution, staying clear of **moving chains** and **live electrical circuits**.

### WARNING

Service and calibration of the Rolloscope should only be performed by qualified personnel.

## 5.2 Preparing for Service

To gain access to some of the components to be serviced it is necessary to work through two cutout openings toward the end of the transport band and/or remove the covers. The procedures are outlined in 5.2.1 and 5.2.2.

The procedure in 5.2.1 requires the use of the optional Transport Band Foot Switch shown in Figure 5-2-a. If not available, please order:

A-121-22-001 Transport Band Foot Switch

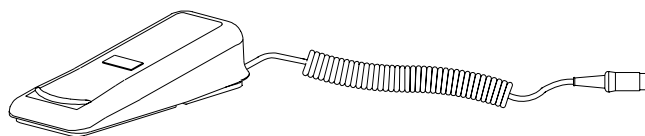

Figure 5-2-a. Transport Band Foot Switch

### 5.2.1 Positioning Transport Band for Service

To access components located behind the transport band, two 15 x 34.5 inches\* cutouts are available near the end of the transport band. See Figure 5-2-b.

There are mainly two areas where the cutouts will help in gaining access to components behind the band.

- Front side of light box.
- Back side of light box.

\* Applies to Rolloscope MD

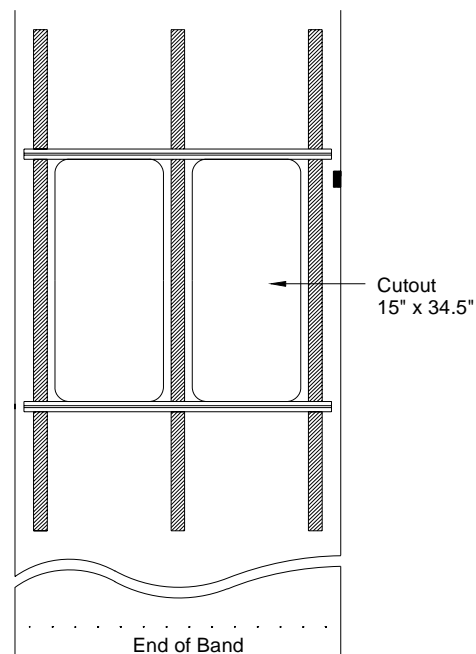

Figure 5-2-b. Cutouts in Transport Band

#### Positioning Cutouts in Front of Light Box

- Turn power on to the Rolloscope.
- Make certain the shutters are fully open and Normal Mode selected. See the operating section of this manual.
- Go to frame 100.
- Turn frame number control to 98 and then press and hold RESET button until the FRAME NO. display stops flashing.
- Turn frame number control to 100 and push the control to enter. The film transport band will now move past frame 100 and stop with the two cutout areas of the band in front of the viewing area. See Figure 5-2-c.
- Turn power off.
- When the service has been completed, turn power on and press NEXT DOWN switch momentarily. The transport band should now move to frame 100 and stop.
- The Rolloscope is now ready for normal operation.

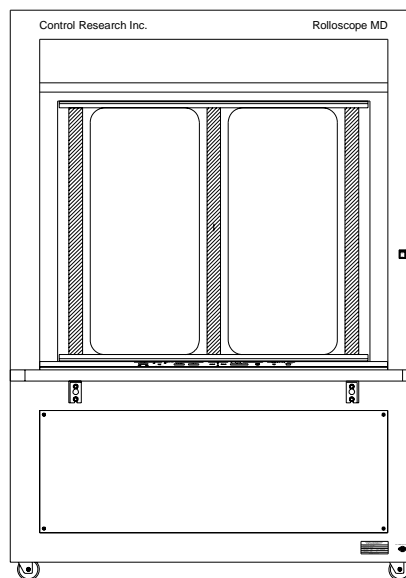

Figure 5-2-c. Cutouts in Front of Light Box

### 5.2.1 Positioning Transport Band for Service, continued

#### Positioning Cutouts in Back of Light Box

In order to drive the transport band further up for the cutouts to be in the back of the light box, it is necessary to disable the right side magnetic sensor, select service mode and use the transport band foot switch.

- a. Turn power on to the Rolloscope.
- b. Make certain the shutters are fully open and Normal Mode selected. See the operating section of this manual.
- c. Go to frame 100.
- d. **Turn power off.**
- e. See section 5.2.2 and remove Cover for Electronics, Back Covers and any other covers as directed in the procedure.
- f. Locate the Relay Interface Board (see Figure 5-3-1) and remove the wire from TB-1 #9 (see Figure 5-2-e). This will disable the magnetic sensor for the up limit and allow the transport band to be driven past its normal end position.
- g. See Figure 5-2-f and set S1 to HIGH speed and S2 to SERVICE MODE.
- h. Connect the Transport Band Foot Switch, shown in Figure 5-2-a.
- i. Turn power on and with the foot switch, drive the transport band up until the cutout is located as shown in Figure 5-2-d.

**CAUTION**

**Do not drive the band any further up.** It is near the end of its travel and could cause damage to the band and the drive.

- j. Turn power off and perform required service.
- k. When the service has been completed, go to the next instruction "Restoring Normal Operation."

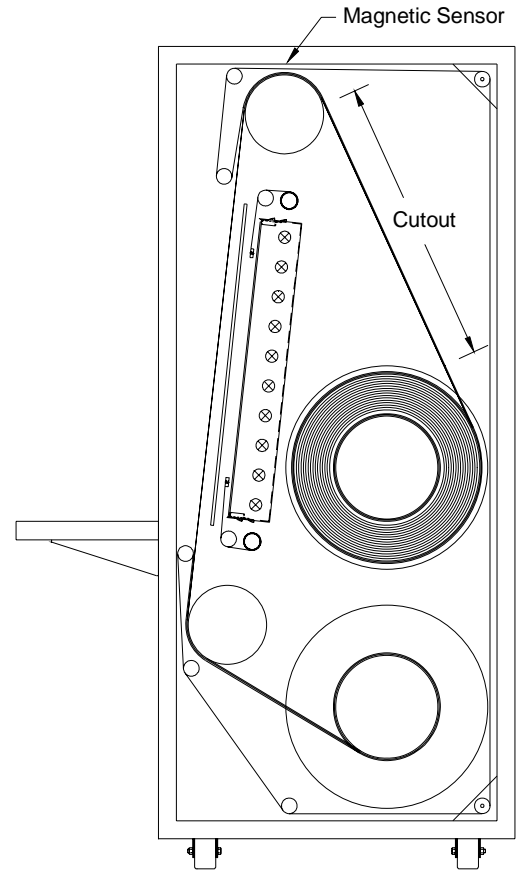

Figure 5-2-d. Cutouts in Back of Light Box

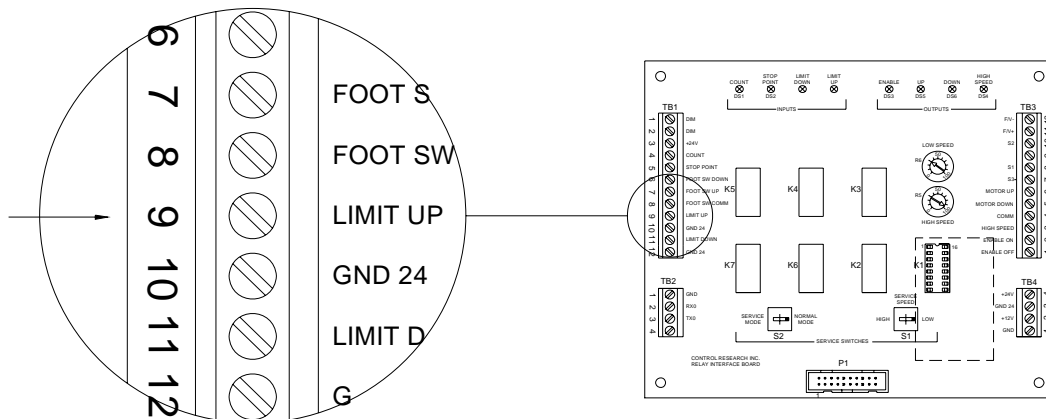

Figure 5-2-e. Disconnecting Magnetic Sensor

### 5.2.1 Positioning Transport Band for Service, continued

#### Restoring Normal Operation

After the cutouts in the transport band have been at the back of the light box and the switches on the relay board have been in service mode, normal operation will be restored by proceeding according to the following:

- a. Turn power on.
- b. With the foot switch drive the band down until the film holder #100 is centered in the viewing area.
- c. **Turn power off.**
- d. Disconnect the transport band foot switch.
- e. See Figure 5-2-g and set S1 to LOW speed and S2 to NORMAL MODE.
- f. Connect the wire removed earlier from TB-1 #9 on the relay interface board. See Figure 5-2-e.
- g. Turn power on.
- h. Dial in the number of the frame presently in the viewing area (frame #100). See Figure 4-3-4.
- i. Press and hold the RESET button, until the display stops flashing.
- j. Check that everything is working normally.
- k. **Turn power off.**
- l. Install covers etc.



Figure 5-2-f. Switches in Service Mode of Operation

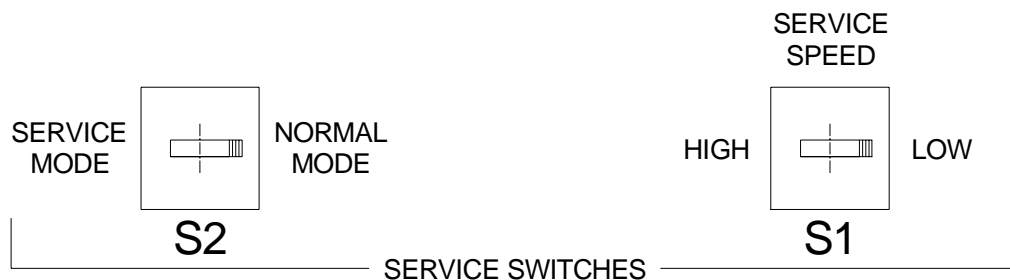

Figure 5-2-g. Switches in Normal Mode of Operation

### 5.2.2 Removing Covers

For service and calibration, it is necessary to remove some of the covers depending on the procedure. All external covers are identified in Figure 5-2-h. To remove the cover(s), proceed as follows:

- a. Make certain that **power is off** and the **line cord is disconnected**.
- b. Remove the cover(s) as directed in the procedure.

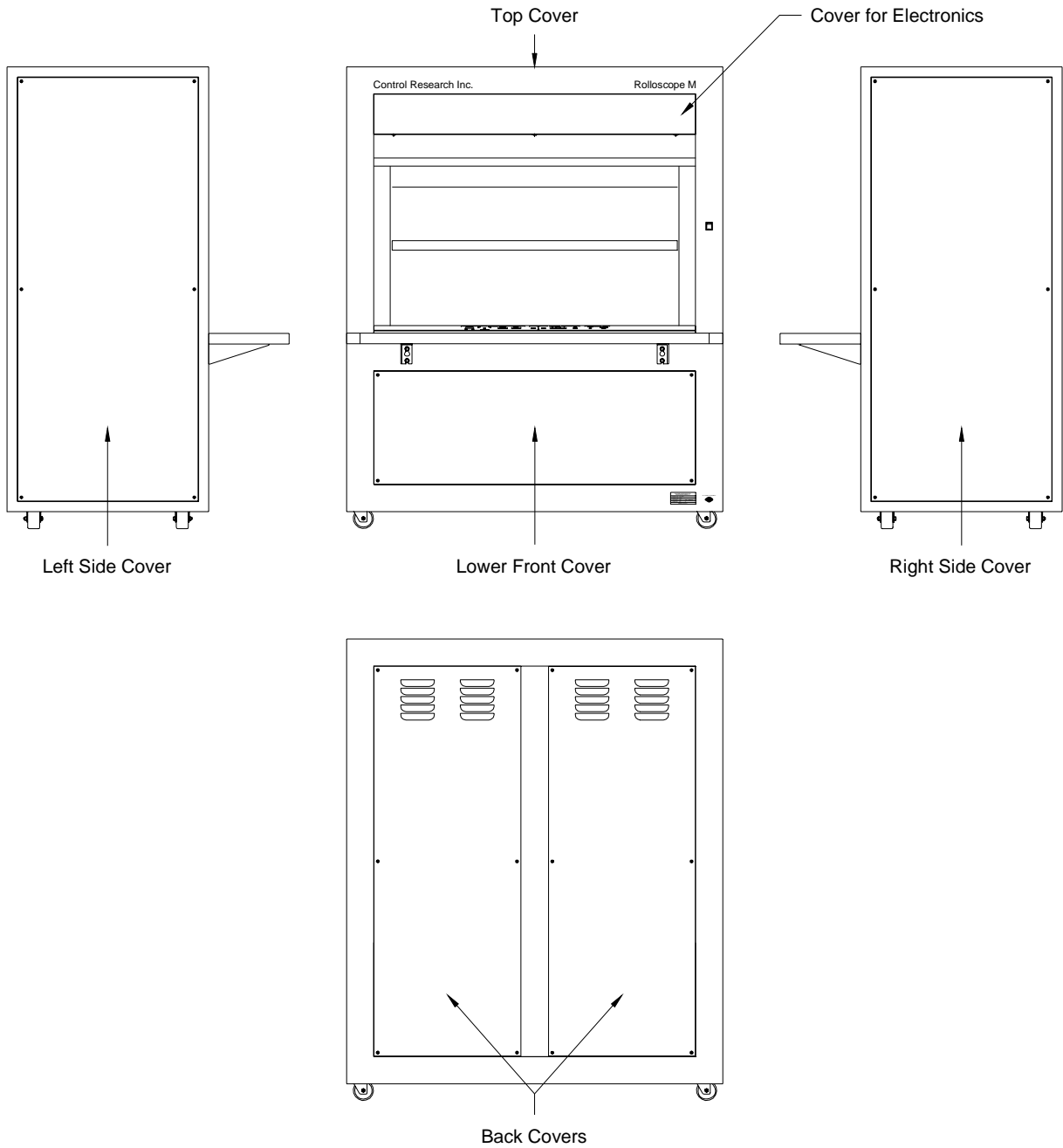

Figure 5-2-h. Removing Covers

### 5.3 Locating PC Boards

There are eight (8) PC Boards located behind the Cover for Electronics, as shown in Figure 5-3-1. In addition, there are two (2) PC Boards integrated with the Control Panel.

In order to gain access to the upper eight PC Boards, make certain **power is off** and the **line cord is disconnected**, then remove the Cover for Electronics as shown in Figure 5-3-1.

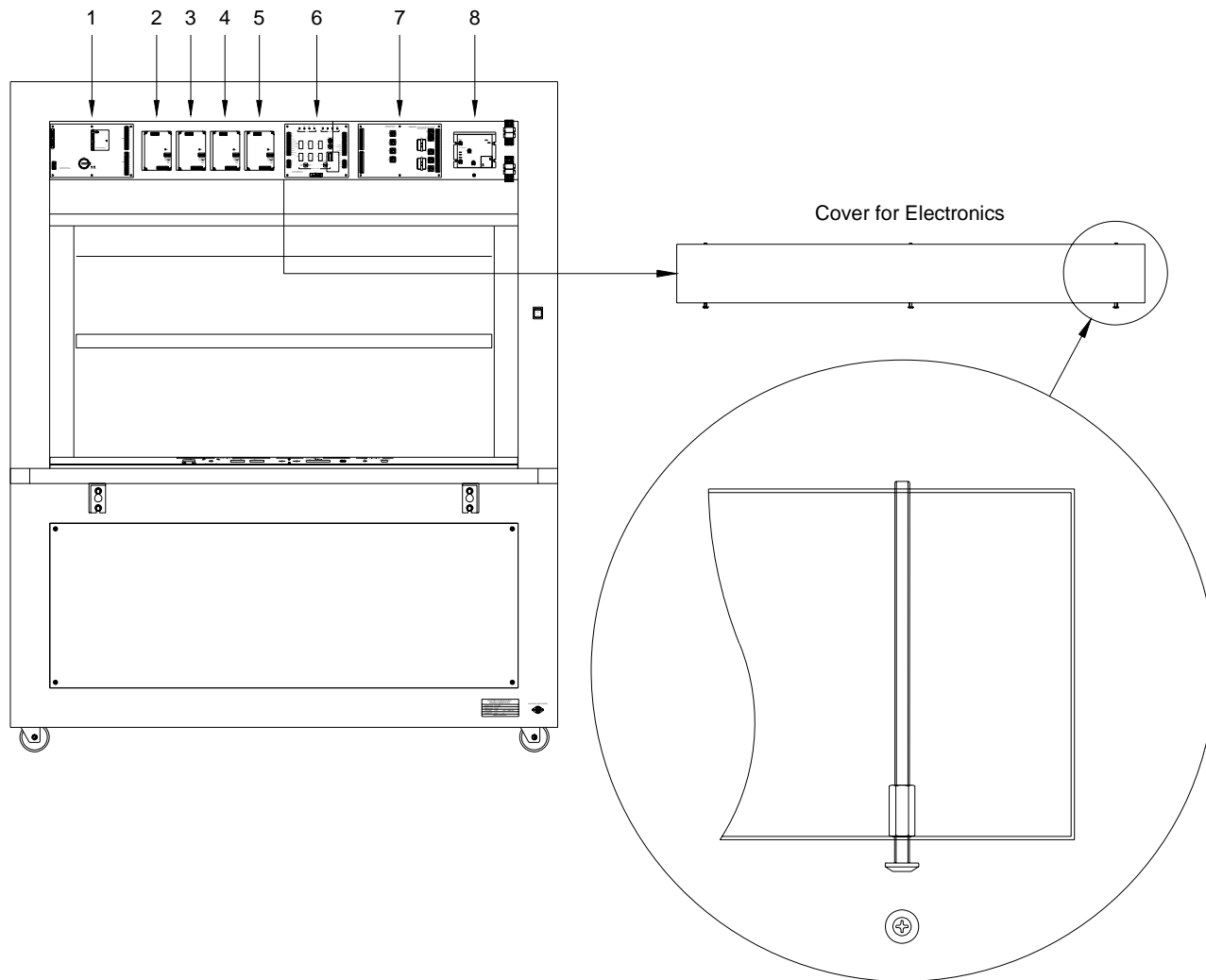

Figure 5-3-1. Locating PC Boards

- |  |  |
|--|--|
| 1. Shutter Control Board                   | 5. Shutter Driver Board, Vertical, Lower |
| 2. Shutter Driver Board, Horizontal, Left  | 6. Relay Interface Board                 |
| 3. Shutter Driver Board, Horizontal, Right | 7. Power Supply Board                    |
| 4. Shutter Driver Board, Vertical, Upper   | 8. DC Motor Drive Board                  |

### 5.4 Fuse Replacement

There are nine (9) fuses as specified in Table 5-4-1. All fuses are located on the Power Supply Board, shown in Figure 5-4-1.

To remove a fuse, use a slotted screw driver and turn fuse holder cap counter clockwise. Then remove the cap and the fuse attached to it.

Fuse	Circuit	Fuse Value	Type	Size
F1	AC Power	10A/250V	Fast Acting*	1-1/4" x 1/4"
F2	AC Power	10A/250V	Fast Acting*	1-1/4" x 1/4"
F3	120 VAC	8A/250V	Fast Acting*	1-1/4" x 1/4"
F4	24 VAC	8A/250V	Fast Acting*	1-1/4" x 1/4"
F5	120 VAC (T2, T3 Prim.)	½ A/250V	Fast Acting*	1-1/4" x 1/4"
F6	Spare Circuit	½ A/250V	Fast Acting*	1-1/4" x 1/4"
F7	5 VAC (Shutter Control Board)	½ A/250V	Fast Acting*	1-1/4" x 1/4"
F8	5 VAC (Opto Isolator)	½ A/250V	Fast Acting*	1-1/4" x 1/4"
F9	12 VAC (Frame Selector)	½ A/250V	Fast Acting*	1-1/4" x 1/4"

Table 5-4-1. Fuse Specifications

\*Littlefuse Series 312 or equivalent.

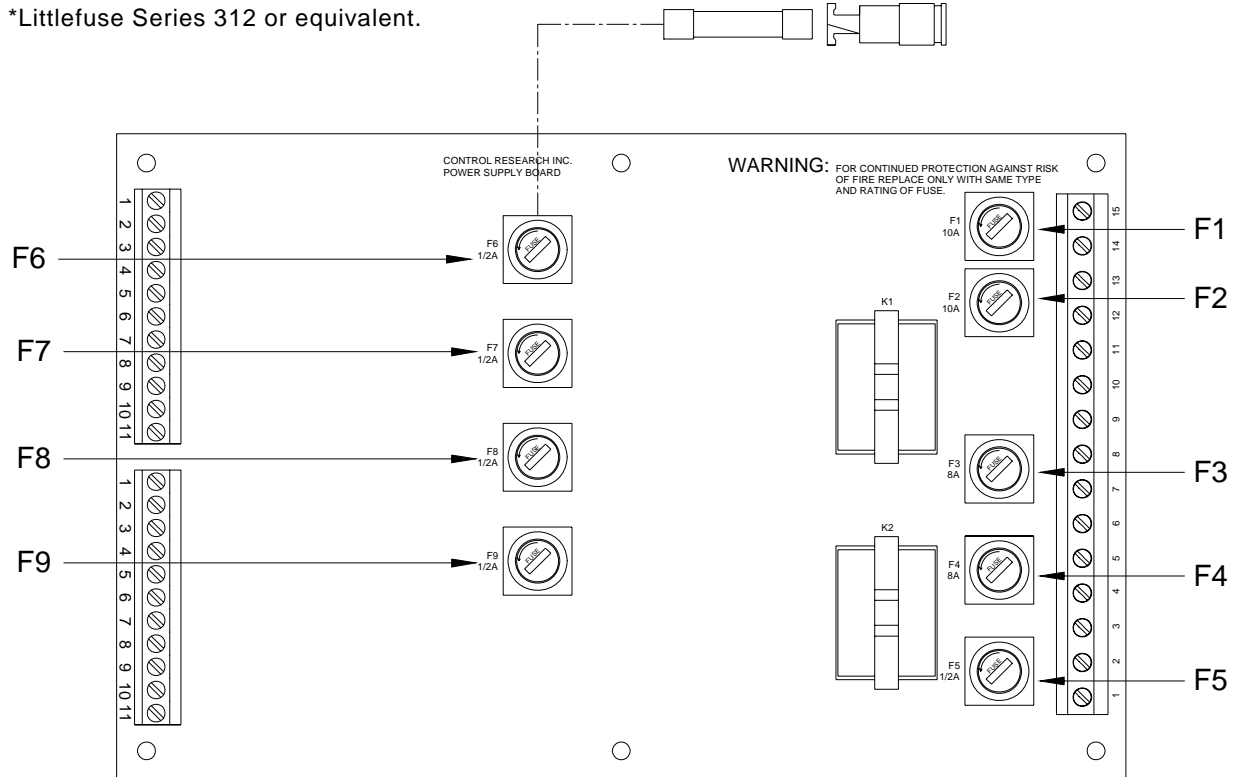

Figure 5-4-1. Fuses on Power Supply Board

## 5.5 Replacing Shutter Shield

The clear acrylic shutter shield is located between the transport band and the shutters. It serves two purposes. First it protects the shutters from the transport band and secondly it facilitates film loading by acting as a back support for the band.

The shutter shield could be damaged if excess force is applied from the front. It would then be necessary to replace it. Also, the shutter shield will have to be removed when changing fluorescent lamps.

### Removing Shutter Shield

The shutter shield has to be removed from the right side of the Rolloscope as shown in Figure 5-5-1. The procedure is as follows:

- Remove Right Side Cover, as shown in section 5.2.
- Loosen two screws and two nuts as shown in the details of Figure 5-5-2.
- See figure 5-5-2 and move Shutter Shield Bracket (1) toward the front and Shutter Shield (2) with its support toward the back of the Rolloscope.
- Pull the Shutter Shield (2) out from its supporting channels as shown in Figure 5-5-1.

### Reinstalling Shutter Shield

- Insert the Shutter Shield (2) into its supporting channels.
- Push the Shutter Shield and its support toward the front of the Rolloscope and tighten the two screws shown in Figure 5-5-2.
- Move the Shutter Shield Bracket (1) toward the back of the Rolloscope until the Shutter Shield (2) is approximately centered between the Transport Band (3) and the front of the Horizontal Shutter (4).
- Tighten the two nuts shown in Figure 5-5-2.
- Reinstall the Right Side Cover.

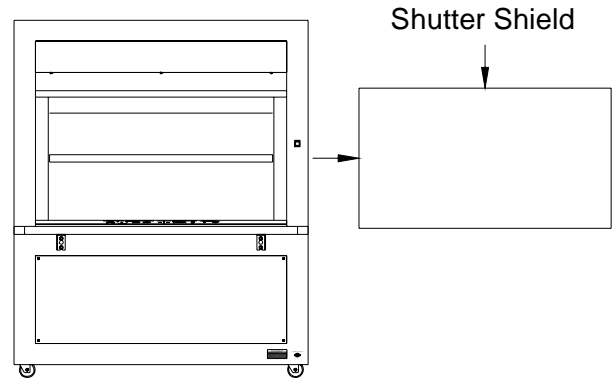

Figure 5-5-1. Shutter Shield

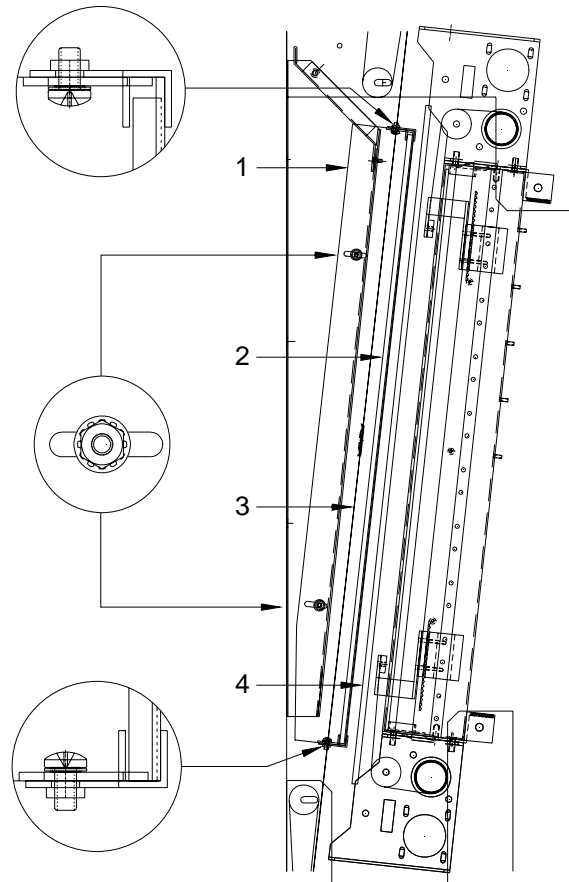

Figure 5-5-2. Shutter Shield, Details

1. Shutter Shield Bracket
2. Shutter Shield
3. Transport Band
4. Horizontal Shutter

## 5.6 Replacing Diffuser

The diffuser is located in the front part of the light box between the fluorescent lamps and X-ray films to be viewed. The purpose with the diffuser is to distribute the light evenly over the entire viewing area.

The diffuser (as well as the shutter shield covered in section 5.5) has to be removed in order to replace the fluorescent lamps.

### Removing Diffuser

The diffuser has to be removed from the right side of the Rolloscope as shown in Figure 5-6-1. The procedure is as follows:

- a. Turn power on to the Rolloscope.
- b. Make certain the shutters are fully open and Normal Mode selected. See the operating section of this manual.
- c. Go to frame 100.
- d. Turn frame number control to 98 and then press and hold RESET button until the FRAME NO. display stops flashing.
- e. Turn frame number control to 100 and push the control to enter. The film transport band will now move past frame 100 and stop with the two cutout areas of the band in front of the viewing area.
- f. Turn power off.
- g. Remove shutter shield as shown in section 5.5.
- h. Remove light box cover as shown in Figure 5-6-2.
- i. Through cutouts in the viewing area, push right end of diffuser toward back of Rolloscope and move it out through the opening in right side of light box.

### Reinstalling Diffuser

- a. Make certain that power is turned off.
- b. Insert diffuser through opening on right side of light box.
- c. Install light box cover. Before tightening the three screws, push cover toward front of Rolloscope. This will hold diffuser firmly in place and prevent it from rattling.
- d. Install shutter shield as shown in section 5.5.
- e. Turn power on and press NEXT DOWN switch momentarily. The transport band should now move to frame 100 and stop. The FRAME NO. display should also show 100.
- f. The Rolloscope is now ready for normal operation.

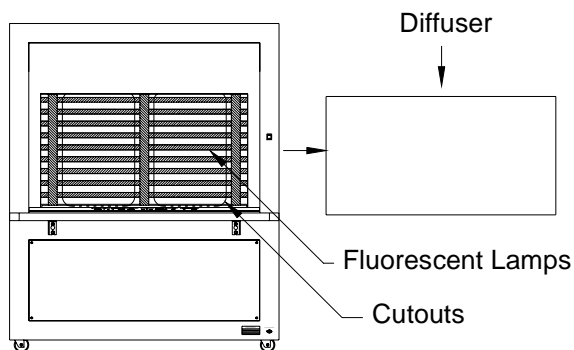

Figure 5-6-1. Diffuser

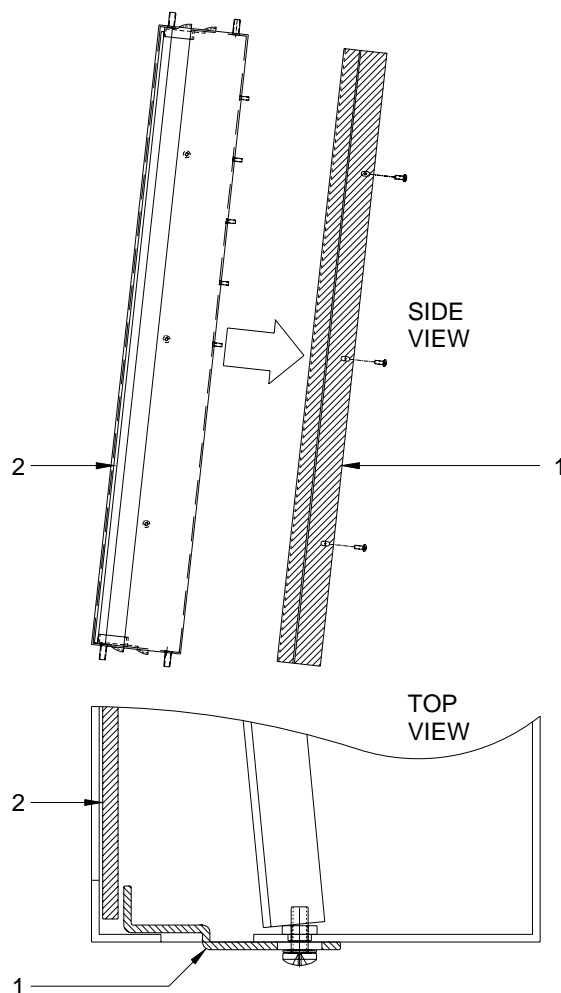

Figure 5-6-2. Removing Diffuser

1. Light Box Cover
2. Diffuser

## 5.7 Replacing Fluorescent Lamps

There are fourteen (14) fluorescent lamps used in the Rolloscope. When replacing lamps due to lamp failure or loss of light output, it is recommended that **all lamps be replaced**, regardless of age or condition. This will give optimum performance, with least amount of service time.

Access to the lamps is from the front of the Rolloscope and through the cutouts at the end of the transport band. Also, it is necessary to remove the shutter shield and the diffuser.

### Preparations

- Remove shutter shield and diffuser by following the instructions under "Removing Diffuser" in section 5.6.
- The viewing area should now look similar to Figure 5-7-1.

### Removing Fluorescent Lamps

**WARNING**

To prevent injury from breakage of the fluorescent lamps, handle the lamps with great care.

- Make certain power is turned off.
- Starting with the bottom lamp, grab the lamp near the ends, turn it 90 degrees and pull it toward the front and out of the lamp holders. Please note that the lamp holders are spring loaded against the ends of the lamp.

- Tilt the lamp with the right end toward the upper right corner of the light box.
- Move the left end of the lamp toward the front and out of the light box. Guide the left end of the lamp down between the transport band and the horizontal shutter until the right end clears the upper right corner of the cutout in the transport band.
- Move the right end of the lamp to the outside of the transport band and remove it at an angle to the upper right.
- Repeat the process for the other nine lamps.

### Installing Fluorescent Lamps

- Install new lamps in reverse order. **Please note that the lamps must be exact replacement.**
- Turn power on and make certain that the lamps are working correctly. Note that some flickering will occur with cold and new lamps. After a few minutes warmup there should be no flickering at any level. Then turn power off.
- Follow the instructions "Reinstalling Diffuser" in section 5.6.
- The Rolloscope should now be ready for normal operation.

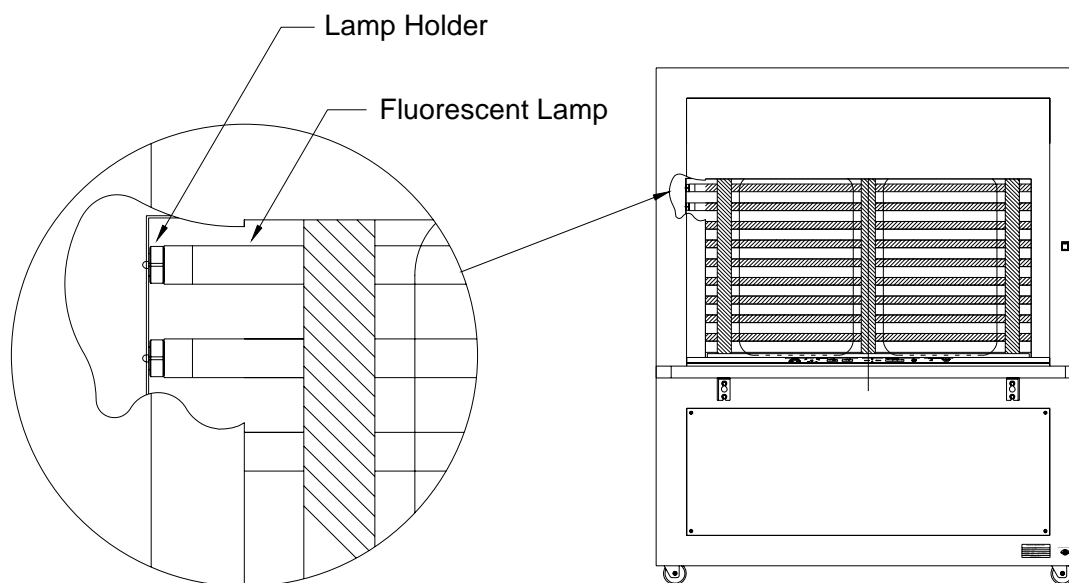

Figure 5-7-1.  
Replacing Fluorescent Lamps

## 5.8 Replacing PC Boards

There are eight (8) PC boards located behind the Cover for Electronics, as shown in Figure 5-3-1. See section 5.3 "Locating PC Boards." There are also two (2) PC boards integrated with the control panel but they will be covered in the section for the control panel.

If it becomes necessary to replace any of the PC boards, consider the following:

- a. Make certain that correct replacement board, valid for the serial number of the Rolloscope, has been ordered.
- b. Make certain **power is turned off**.
- c. Remove the Cover for Electronics, as shown in Figure 5-3-1.
- d. Mark the wires connected to terminal boards with the terminal identification, ex. TB1-3 or TB3-4.
- e. After disconnecting all wires and connectors, remove screws, washers and spacers, holding the board, carefully noting their number, size and location.
- f. Install the new board using same screws, washers and spacers.
- g. Connect marked wires and connectors.
- h. Unless advised differently by instructions accompanying the new board, set all switches and controls preliminarily to the same settings as on the old board.
- i. After board replacement, always **carry out final check and adjustments** for the functions involved, as described in the Maintenance Section of this manual.
- j. Install the Cover for Electronics.

## 5.9 Servicing Control Panel

The control panel is shown in Figure 5-9-1. There are two different enclosures for the control panel. One for the MD (allowing use of monitors) and one for the MP. To replace parts of the control panel, follow the steps for the model involved.

- A. Control Panel for Rolloscope MD.
- B. Control Panel for Rolloscope MP.

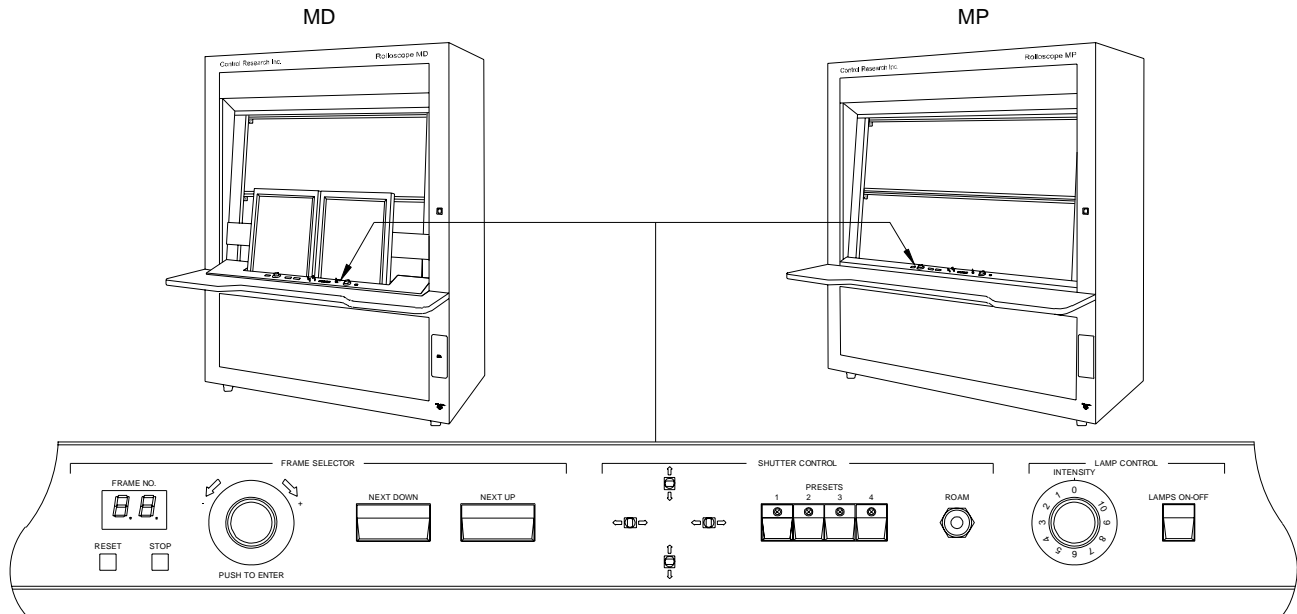

Figure 5-9-1. Control Panel

### 5.9.1 Preparation for Servicing Control Panel

#### A. Rolloscope MD, see Figure 5-9-2A.

To replace parts in the control panel, it is necessary to first remove the table and then the control panel cover.

The following steps describe the procedure:

#### Removing the Table

The table (2) is mounted to the Rolloscope with four bolts (3). To remove the table, proceed as follows:

- a. Use a ½ inch socket wrench and loosen four bolts (3).
- b. The table brackets (1) have slotted holes for easy removal of the table. Lift the table (2) up and away from the Rolloscope.

#### Removing the Control Panel Cover

- a. Make certain that **power is turned off**.
- b. If monitors are used, remove monitors.
- c. Tilt control panel (4a and 4b) up as shown in 4b.
- d. Remove bottom cover.

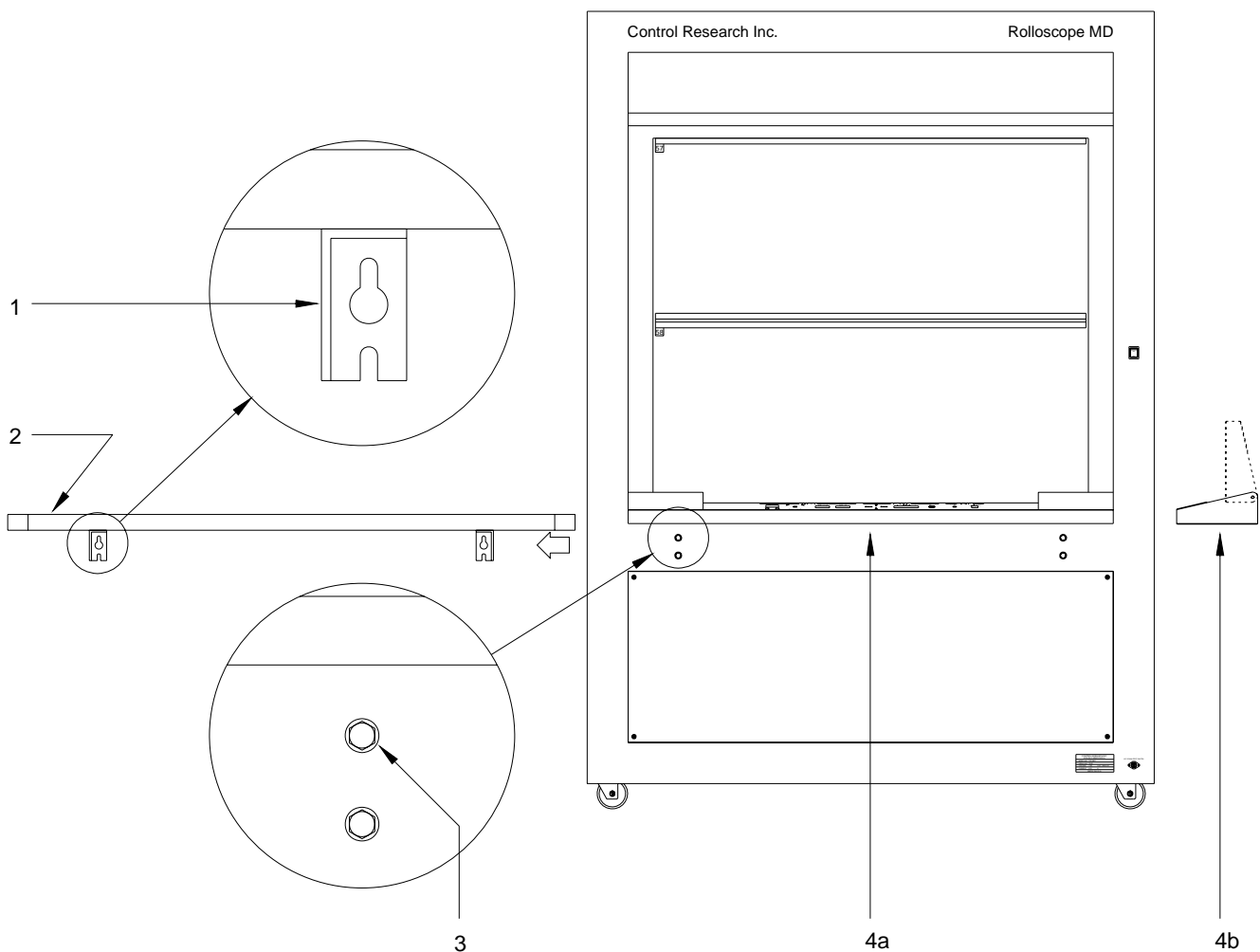

Figure 5-9-2A. Removing Table and Control Panel Cover

### 5.9.1 Preparation for Servicing Control Panel, continued

#### B. Rolloscope MP, see Figure 5-9-2B.

To replace parts in the control panel, it is necessary to first remove the table and then the control panel.

The following steps describe the procedure:

#### Removing the Table

The table (2) is mounted to the Rolloscope with four bolts (4). To remove the table, proceed as follows:

- e. Use a ½ inch socket wrench and loosen four bolts (4).
- f. The table brackets (1) have slotted holes for easy removal of the table. Lift the table (2) up and away from the Rolloscope.

#### Removing the Control Panel

The control panel (5) is secured by three screws (3). To remove the control panel, proceed as follows:

- a. Make certain that **power is turned off**.
- b. Remove three screws (3)
- c. Lift the control panel (5) straight up and disconnect the two ribbon cables.
- d. Move the control panel assembly to a work area where the control panel can be supported in both ends with the controls turned downwards.

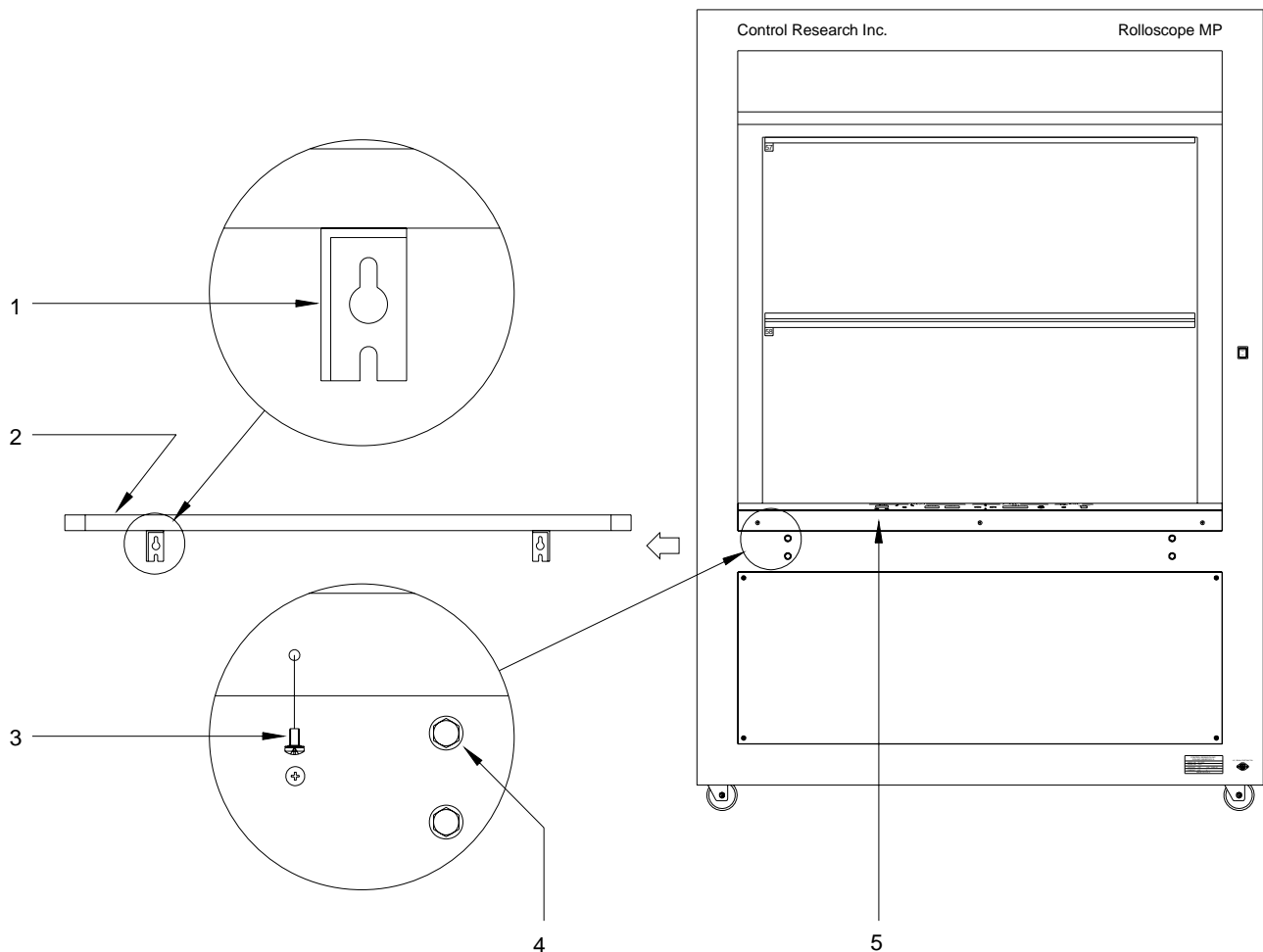

Figure 5-9-2B. Removing Table and Control Panel

### 5-9-2 Replacing Rotary Encoder (6), see Figure 5-9-3

#### Removing rotary encoder:

- a. Remove the table and prepare control panel as described in section 5.9.1, A or B.
- b. Remove knob (7).
- c. Remove flexible cable (5).
- d. Use 9/16" wrench and remove nut holding rotary encoder (6) to control panel.
- e. Lift rotary encoder with its mounting hardware out and away from the control panel.

#### Installing replacement rotary encoder:

- a. Make certain that the same washers/spacers are used and install the rotary encoder in reverse order.
- b. Verify that the "Push to enter" switch clicks just before the knob hits the control panel. If not, adjust height position of knob. Do not over tighten the set screws.
- c. Reinstall control panel and table.
- d. Test and adjust according to procedures outlined in the maintenance and calibration section of this manual.

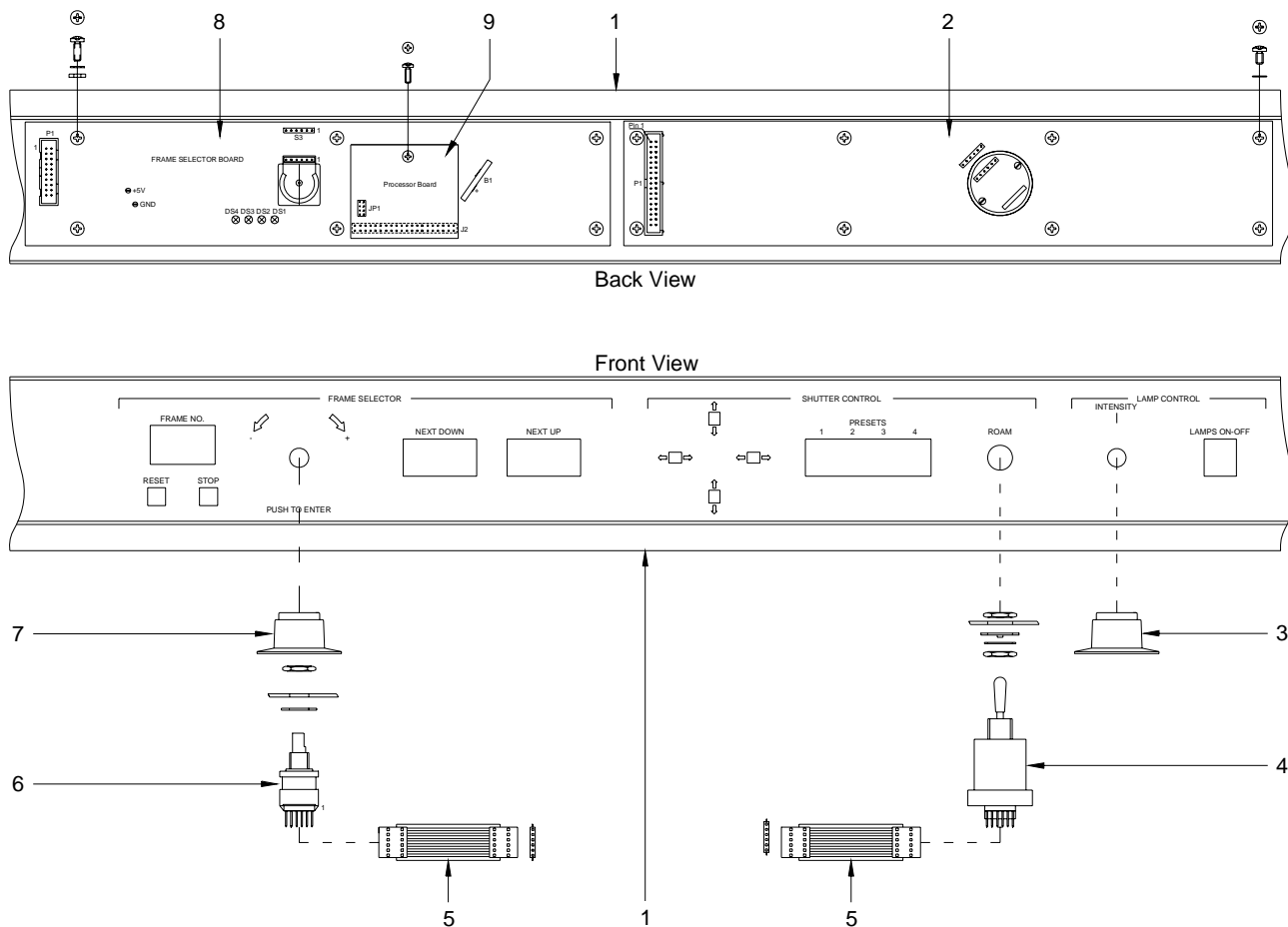

Figure 5-9-3. Control panel Components

- |  |   |
|--|---|
| <ol style="list-style-type: none"> <li>1. Control Panel, Silk Screened</li> <li>2. Shutter Switch Board</li> <li>3. Knob for Dimmer</li> <li>4. Shutter Joy Stick</li> <li>5. Flexible Cable Assembly</li> </ol> | <ol style="list-style-type: none"> <li>6. Rotary Encoder</li> <li>7. Knob for Frame Selector</li> <li>8. Frame Selector Board</li> <li>9. Frame Selector CPU Board</li> </ol> |
|--|---|

### 5.9.3 Replacing Shutter Joy Stick (4), see Figure 5-9-3

#### Removing shutter joy stick:

- a. Remove the table and prepare control panel as described in section 5.9.1, A or B.
- b. Remove flexible cable (5).
- c. Use 9/16" wrench and remove nut holding shutter joy stick (4) to control panel.
- d. Lift shutter joy stick with its mounting hardware out and away from the control panel.

#### Installing replacement shutter joy stick:

- a. Make certain that the same washers/spacers are used and install the shutter joy stick in reverse order.
- b. Reinstall control panel and table.
- c. Test and adjust according to procedures outlined in the maintenance and calibration section of this manual.

### 5.9.4 Replacing Frame Selector Board (8), see Figure 5-9-3

#### Removing frame selector board:

- a. Remove the table and prepare control panel as described in section 5.9.1, A or B.
- b. Remove flexible cable (5) connecting rotary encoder to frame selector board.
- c. Remove screws holding frame selector board to control panel and lift out frame selector board.

**Note:** The frame selector CPU board (9) is not part of the frame selector board (8) and has to be ordered separately.

#### Installing replacement frame selector board:

- a. Transfer CPU board from the old frame selector board to the new frame selector board.
- b. Install frame selector board in reverse order.
- c. Reinstall control panel and table.
- d. Test and adjust according to procedures outlined in the maintenance and calibration section of this manual.

### 5.9.5 Replacing Shutter Switch Board (2), see Figure 5-9-3

#### Removing shutter switch board:

- a. Remove the table and prepare control panel as described in section 5.9.1, A or B.
- b. Remove knob for dimmer (3).
- c. Remove flexible cable (5) connecting shutter joy stick to shutter switch board.
- d. Remove screws holding shutter switch board to control panel and lift out shutter switch board.

#### Installing replacement shutter switch board:

- a. Install shutter switch board in reverse order.
- b. Reinstall control panel and table.
- c. Test and adjust according to procedures outlined in the maintenance and calibration section of this manual.

## 5.10 Replacing Batteries

There are two (2) lithium batteries used to retain memory. One is located on the shutter control board and one on the frame selector board.

The batteries have an expected life of five years. When the battery voltage drops below 2.0 volts or when the shutter or frame control settings are lost, the batteries should be replaced.

To replace the batteries, see Figure 5-10-1 and proceed as follows:

### Shutter Control Board

- See section 5.3 and locate the shutter control board.
- Use a small screwdriver and carefully lift the left side of the battery and push it out and away from the contact on top.
- Install the new battery by pushing it under the contact and into the holder.
- Check that the voltage is  $3.1 \pm 0.2$  volts.

### Frame Selector Board

- Remove the frame selector board from the Rolloscope as instructed in section 5.9.4.
- Desolder the old battery and install the new.
- Check that the voltage is  $3.1 \pm 0.2$  volts.
- Reinstall the board and check operation.

**Note:** All shutter and frame control settings stored in memory will be lost and have to be reset.

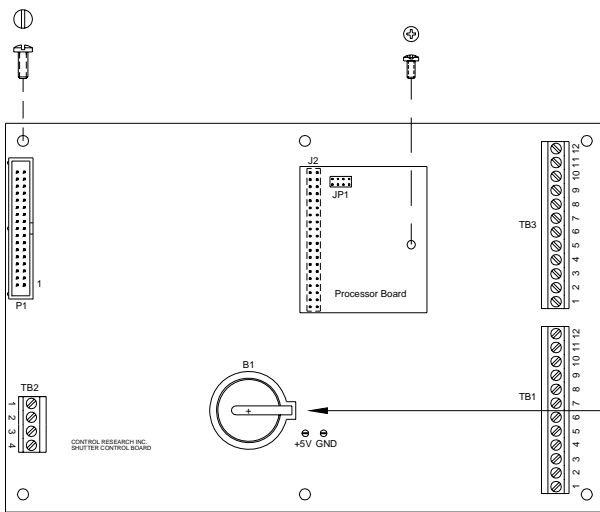

Shutter Control Board

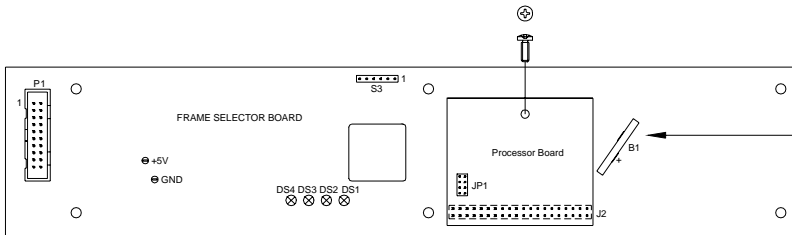

Frame Selector Board

Figure 5-10-1. Replacing Batteries

## 5.11 Replacing Anti-Static Brushes

To minimize static buildups, two sets of anti-static brushes (2 in Figure 5-11-1) are used. Each brush (3) is only 24 inches long and therefore two brushes have to be used with each set to cover the width of the transport band. To replace the brushes, proceed as follows:

### Upper Set

- Remove top, right and left side covers as described in section 5.2.
- The brushes are mounted to a hex rod (1) held to the right and left side bracket with 1/4" hex bolts. Remove the two hex bolts and pull the hex rod out from the top of the Rolloscope.
- Replace the two brushes and install the rod in reverse order.

### Lower Set (Applies to Rolloscope MP only)

- Remove the complete control panel assembly as described in section 5.9.
- Remove bracket for control panel mounting (5). It is held to the Rolloscope frame with five screws (4).
- Remove old brushes and install new.
- Assemble in reverse order.

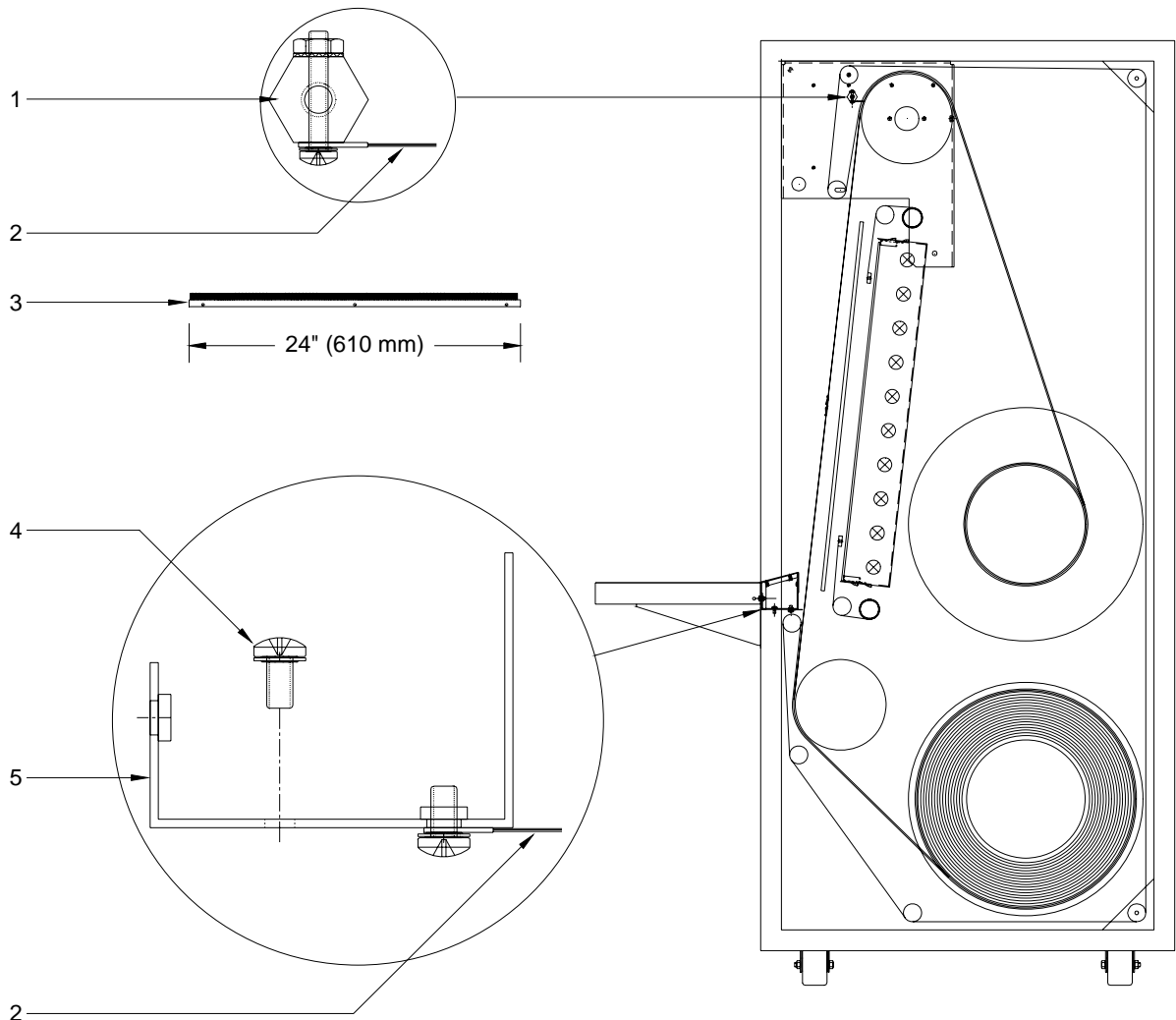

Figure 5-11-1. Anti-Static Brushes

## 5.12 Replacing Ballasts

There are six electronic dimming ballasts in the Rolloscope. They are mounted on the back of the light box as shown in Figure 5-12-1.

Each ballast controls two fluorescent lamps. In order to maintain the high, flicker free, light output, it is important to **use only exact replacement ballast**.

To replace the ballast, proceed as follows:

- a. Make certain **power is off** and the **line cord disconnected**.
- b. Remove right, left and back covers as described in section 5.2.2.
- c. Follow the instructions in section 5.2.1 and position the cutouts in the transport band in the back of the light box.
- d. **Turn power off.**
- e. Make a sketch and mark the wires connected to the ballast to be replaced.
- f. With a screw driver push down the wire release tab and pull out each wire from the ballast.
- g. Loosen the nut in one end of the ballast.
- h. Remove the nut in the other end and lift out the ballast.
- i. Install the new ballast in reverse order.
- j. Turn power on and check that the light output is uniform and that the intensity can be controlled throughout its full range.
- k. Restore normal operation by following the steps for "Restoring Normal Operation" in section 5.2.1.

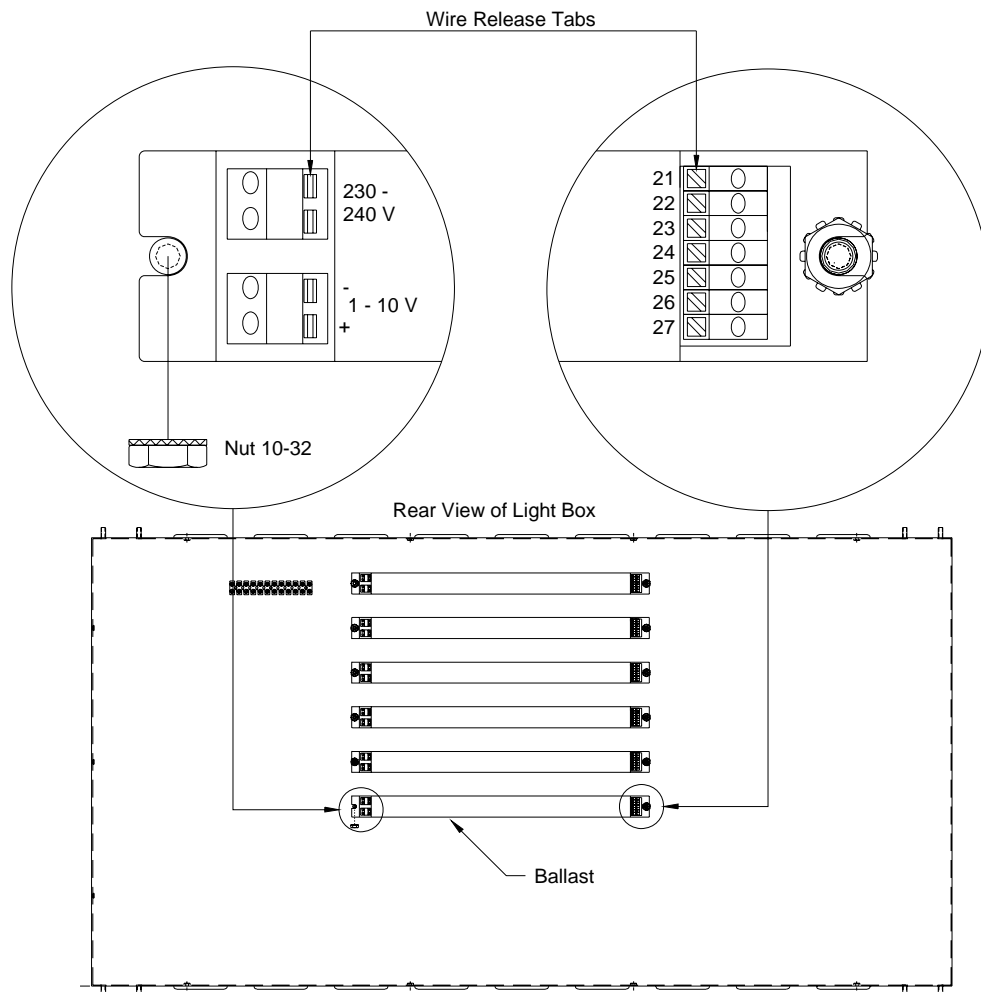

Figure 5-12-1. Replacing Ballasts

### 5.13 Servicing Transport Band Drive

#### Principle of Operation

Figure 5-13 shows the principle of operation of the transport band drive. Following is a short description of the operation:

When the operator selects a frame or activates the up or down switches on the Frame Selector (1), a signal goes to the Relay Interface Board (2). From there the signal goes to the Motor Drive Board (3) which provides power to the DC Motor (4).

The DC Motor (4) drives the Transport Band (7) in the direction determined by selection made on the Frame Selector (1) and continues until the desired frame has been reached.

To maintain a constant speed for Transport Band (7) a Sprocket Gear is driven by the Band and a Gear Tooth Sensor(5) monitors the speed by reading each tooth on the sprocket wheel. This signal is then sent to a Frequency/Voltage Converter(6). The DC voltage from the converter is sent back to the Relay Interface Board (2) which adjusts the speed of the DC Motor (4).

For keeping track of the frame count and stopping the Transport Band (7) at the correct position, two Photo Sensors (8 and 10) are used. The Photo Sensors are activated by black labels placed along the sides of the Transport Band. In normal (mammography) mode the left sensor is used for frame counting and the right side sensor for stopping point. In full frame mode the functions are reversed.

As an added security, to make certain the band will not go past its end position, two Magnetic Sensors (9 and 11) are used. The Magnetic Sensors will be activated only if the Photo Sensors fail.

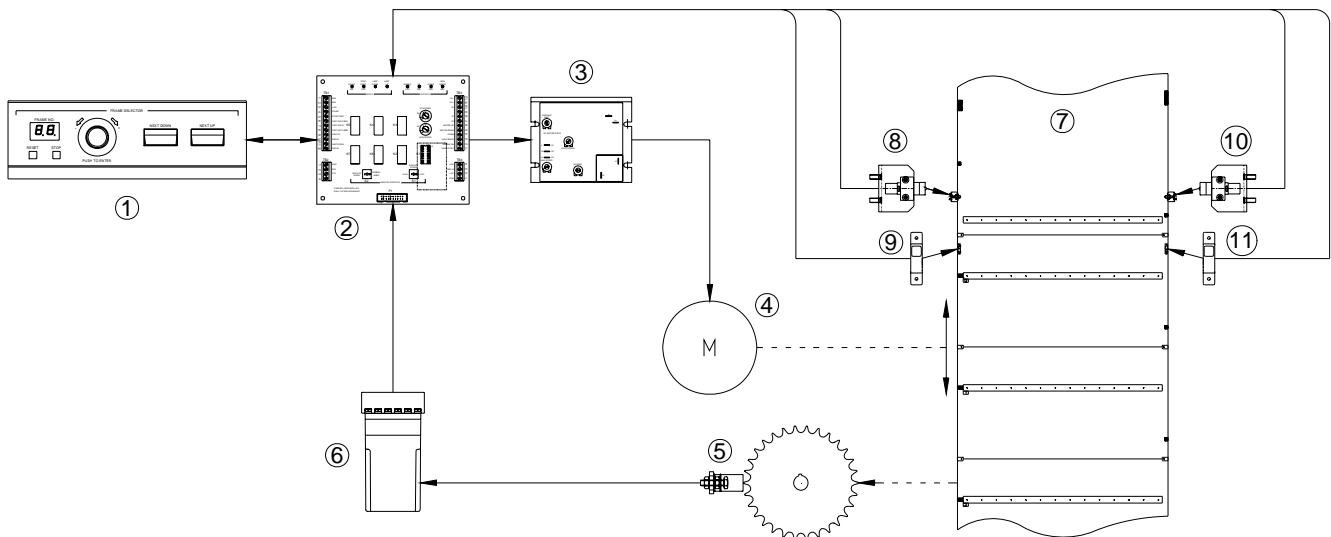

Figure 5-13. Transport Band Drive

- 1. Frame Selector
- 2. Relay Interface Board
- 3. Motor Drive Board
- 4. DC Motor
- 5. Gear Tooth Sensor
- 6. Frequency/Voltage Converter

- 7. Transport Band
- 8. Photo Sensor, Left Side
- 9. Magnetic Sensor, Left Side
- 10. Photo Sensor, Right Side
- 11. Magnetic Sensor, Right Side

### 5.13 Servicing Transport Band Drive, continued

#### Trouble Shooting the Transport Band Drive

When trouble shooting the transport band drive, carefully observe and record what is happening? First look for the most likely causes as the ones listed below. If this does not solve the problem, check the calibrations and adjustments as outlined in the Maintenance Section of this manual.

**WARNING**

Disconnect the power cord before removing any of the covers. Should it be necessary to operate the unit with the covers off, exercise extreme caution, staying clear of **moving chains** and **live electrical circuits**.

SYMPTOM	CHECK/ADJUST
Transport band stops with the film holder 8" - 9" from the top of the viewing area.	High Film Clip Mode has been selected. To return to Normal Mode, press and hold the STOP button for more than 2 seconds. See the Operating section of this manual.
FRAME NO. display does not correspond to the frame number in the viewing area.	Dial in the number of the frame presently in view. Press and hold the RESET button until the display stops flashing. See the Operating section of this manual.
Transport band will stop before, or go past selected frame. Frame number display shows "0" or "100" even though the band is not at the end position.	Films placed too close to the edge of the transport band. This will disturb the photo sensors.
Transport band slows down when reaching the selected frame but does not stop. Instead, it continues at low speed until power is turned off.	Stop point photo sensor not operating. Check stop point photo sensor (right side sensor in Normal Mode) by blocking the beam. The red LED on the sensor should go off and the output (black wire) should go from 24 V to 0 V. If it does not, replace the sensor (section 5.13.4).
Transport band overshoots the stopping point by several inches (stopping point of band too high going up, too low going down).	The switch "Service Speed High/Low" on the relay interface board has inadvertently been left in position "High". Return the switch to its normal "Low" position.
Transport band will not move in either direction. Frame selector is frozen on one number and it appear to be flashing slowly.	Severe electrical or static noise has corrupted CPU memory beyond watchdog reset capability. Perform "Super Reset" as follows: Turn power off. Hold RESET button on the frame selector down (see the operating section of this manual) while turning main power on. This will clear the memory and the FRAME NO. display will flash "0". Dial in the number of the frame presently in view. Press and hold the RESET button until the display stops flashing

#### 5.13.1 Replacing PC Boards for Transport Band Drive

Three PC Boards, as shown in Figure 5-13, are directly involved in the transport band drive. They are, the Frame Selector Board, the Relay Interface Board and the Motor Drive Board. The Power Supply Board (see Figure 5-3-1) is also involved as it provides power for the transport band drive.

To replace the boards, follow the directions in sections 5.8 and 5.9.

After board replacement, check and calibrate according to instructions in the Maintenance and Calibration section of this manual.

### 5.13.2 Replacing DC Motor

The DC Motor (see Figure 5-13-a) is a very reliable component and is not expected to need replacement. Should replacement, however, be needed, please proceed as follows:

- a. Drive the transport band to frame No. 50 (mid-point of band = equilibrium), then turn power off.
- b. Using a wrench, loosen the three bolts, holding the motor, to slacken the chain.
- c. Remove the chain and the motor.
- d. Install the new motor and tension the chain for a maximum deflection of ½ inch when pushing at the mid-point of the chain. Tighten the three bolts.
- e. Reset the Frame No. on the frame selector if needed and verify correct operation.

**WARNING**

**DO NOT REMOVE LEFT SIDE CHAIN**  
between upper and lower take-up reels.  
The lower take-up reel contains a spring which  
**CAN CAUSE SERIOUS INJURY.**  
A special tool is needed to un-wind tension.  
Contact Control Research, Inc. before  
attempting any work in this area.

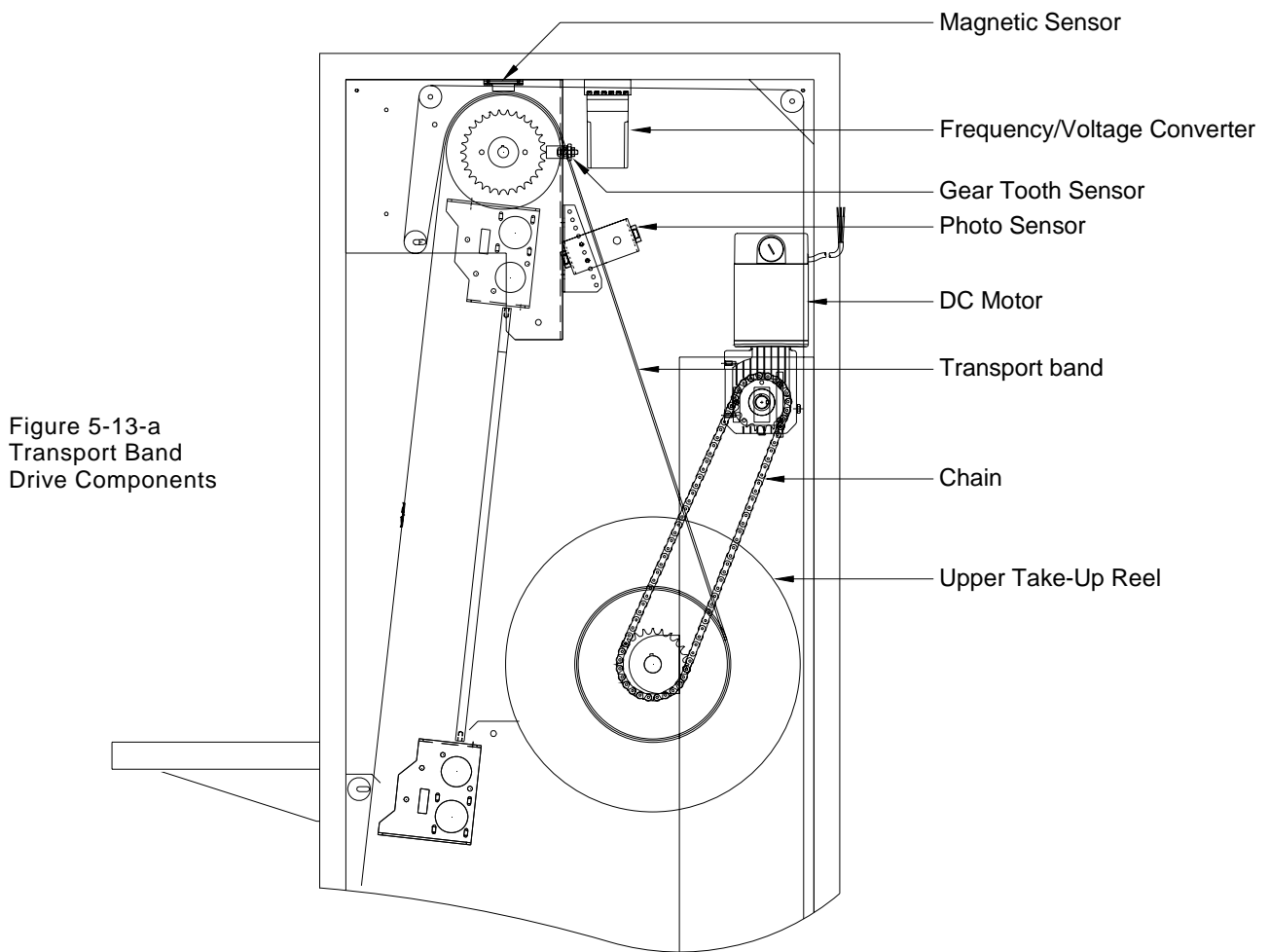

### 5.13.3 Replacing Magnetic Sensor

There are two magnetic sensors (see Figures 5-13 and 5-13-a) to stop the transport band in its end positions. The magnetic sensors are activated only if the photo sensors should fail.

The magnetic sensor on the right side stops the transport band at the end when the band is going up.

The magnetic sensor on the left side stops the transport band at the end when the band is going down.

To replace the magnetic sensor, see Figure 5-13-b and proceed as follows:

- a. Remove top, right and/or left side covers as described in section 5.2.
- b. Disconnect the four wires from terminal strip (2).
- c. Remove two screws (5 in Figure 5-13-b) holding the bracket (4) to the upper side frame member (1) and remove the assembly from the Rolloscope.
- d. Remove the magnetic sensor (3) from bracket (4) and install the new sensor.
- e. Complete the installation in the reverse order.
- f. Check and adjust according to instructions in the maintenance section of this manual.

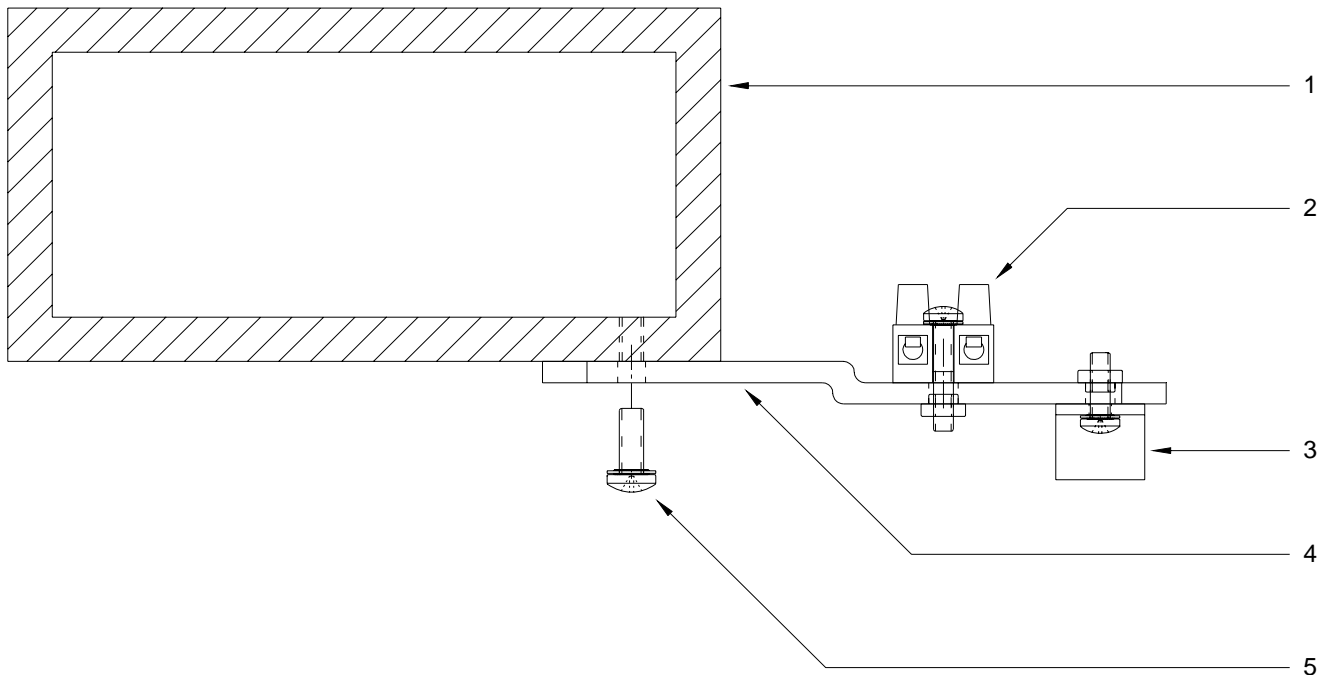

Figure 5-13-b. Replacing Magnetic Sensor

### 5.13.4 Replacing Photo Sensor

There are two photo sensors (see Figures 5-13 and 5-13-a) used to keep track of the frame count and to stop the transport band in the correct position.

Each photo sensor consists of two parts, the emitter and the receiver. When ordering replacement, both parts are delivered as a kit.

To replace the photo sensor, see Figure 5-13-c and proceed as follows:

- a. Remove right, left and back covers as described in section 5.2.2.
- b. Disconnect connectors at emitter and receiver.
- c. Remove screws and nuts (2 for each) holding the emitter and the receiver to the bracket. Note: It may be beneficial to remove the bracket from its support in order to gain better access to emitter connector and screws.
- d. Install the new emitter and receiver.
- e. Complete the installation in reverse order.

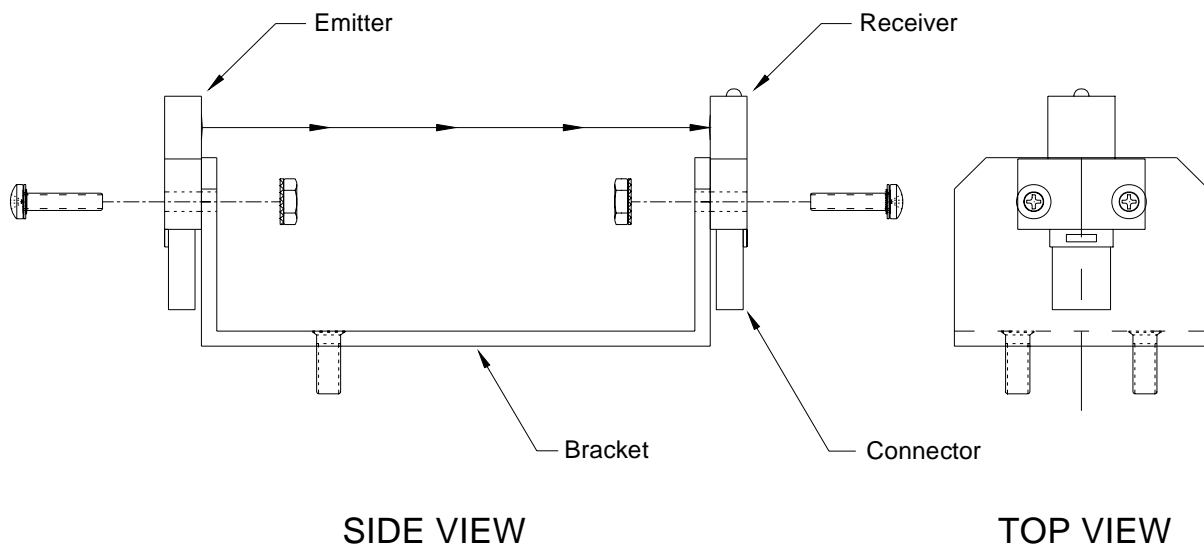

Figure 5-13-c. Replacing Photo Sensor

### 5.13.5 Replacing Gear Tooth Sensor

The gear tooth sensor is a component used to maintain a constant speed of the transport band. For a principle of operation and for the location of the gear tooth sensor, see Figures 5-13 and 5-13-a. As shown in Figure 5-13-d, the gear tooth sensor is attached to the upper right side support bracket (3).

To replace the gear tooth sensor, see Figure 5-13-d and proceed as follows:

- a. Remove right and back covers as described in section 5.2.2.
- b. Locate the three wires from the gear tooth sensor and make a sketch showing their connection to the socket of the frequency/voltage converter.

- c. Disconnect the three wires.
- d. Remove the nut (5 in Figure 5-13-d) and lift out the gear tooth sensor.
- e. Install the new gear tooth sensor in reverse order.
- f. Check that the air gap (a) between the tip of the tooth of sprocket (1) and the front of the gear tooth sensor (2) is between 0.04" and 0.08" (1.0 and 2.0 mm). If necessary, use a flat washer (4) with a different thickness.
- g. Complete the installation in reverse order.
- h. Check and adjust according to instructions in the maintenance and calibration section of this manual.

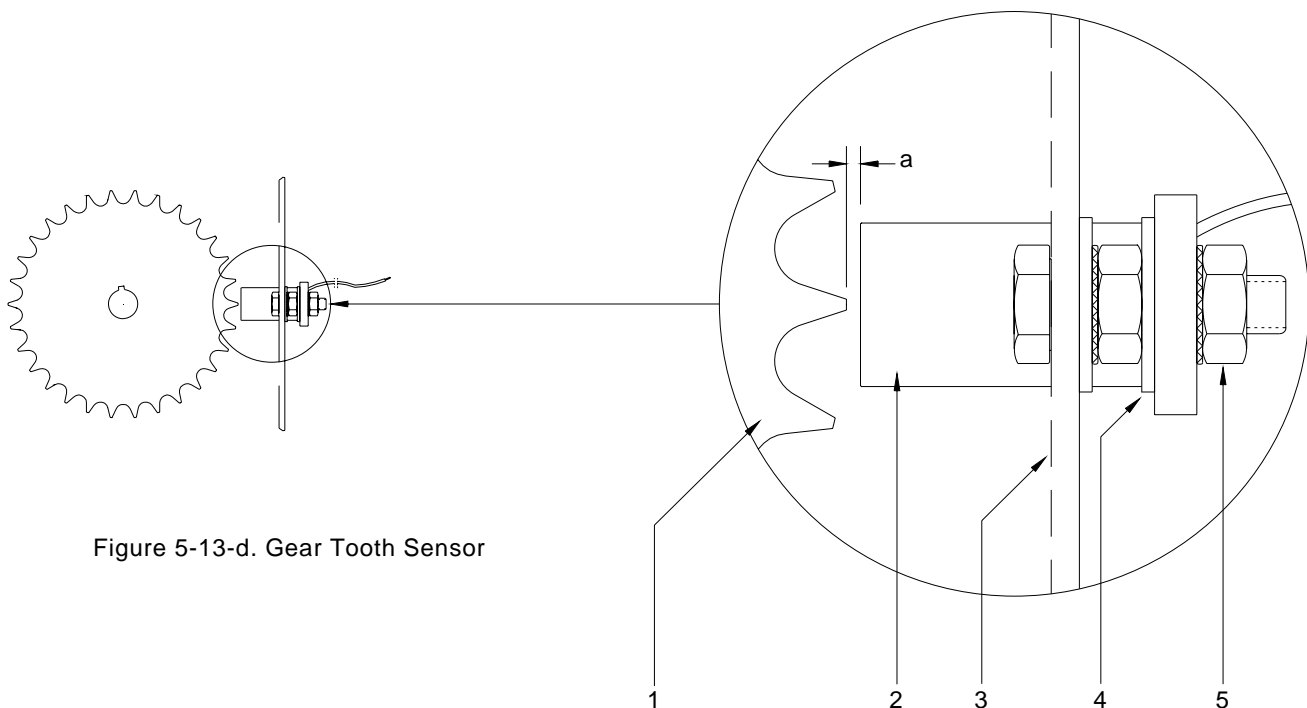

Figure 5-13-d. Gear Tooth Sensor

### 5.13.6 Replacing Frequency/Voltage Converter

The frequency/voltage converter as shown in Figures 5-13 and 5-13-a is a plug-in module and it therefore easy to replace. To replace it, perform the following steps:

- a. Remove right side cover as described in section 5.2.
- b. If the frequency/voltage converter is held to its socket with a cable tie, cut the cable tie.
- c. Pull the frequency/voltage converter out of the socket and install the new one.
- d. Complete the installation in reverse order.
- e. Check and adjust according to instructions in the maintenance and calibration section of this manual.

## 5.14 Servicing Shutter Drive

### Principle of Operation

Figures 5-14-a and 5-14-b show the principle of operation of the shutter drive. Following is a short description of the operation:

Each of the four shutters is controlled by a Step Motor M2, M3, M4 and M5 (see Figure 5-14-b).

From the Shutter Control (1) the operator uses the directional switches, the preset or the roam control to move the shutters to their desired position.

The signal goes from the Shutter Control (1) to the Shutter Control Board (2) which directs the information to the appropriate Step Motor Driver (3, 4, 5 or 6) and on to the Step Motors.

A micro processor and a battery powered memory on the Shutter Control Board (2) keeps track of the shutter positions for the preset and for each frame.

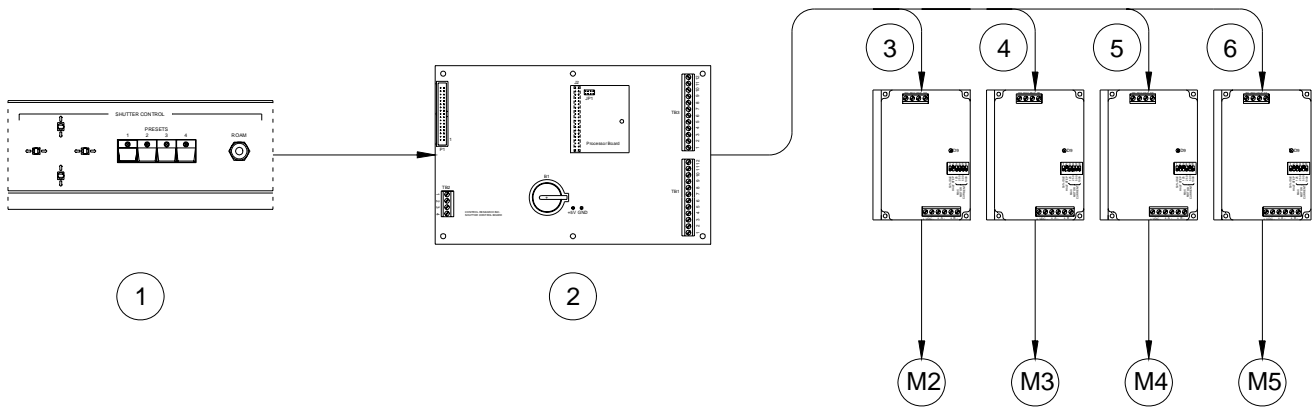

Figure 5-14-a. Shutter Control

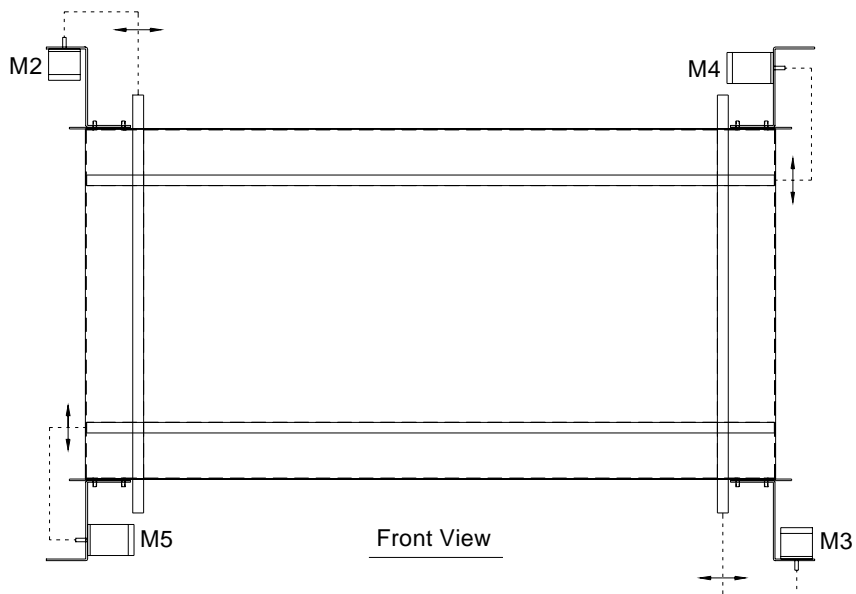

Figure 5-14-b. Shutter Motors

## 5.14 Servicing Shutter Drive, continued

### Trouble Shooting the Shutter Drive

When trouble shooting the shutter drive, carefully observe and record what is happening. First look for the most likely causes as the ones listed below. If this does not solve the problem, check the calibrations and adjustments as outlined in the Maintenance and Calibration Section of this manual.

**WARNING**

Disconnect the power cord before removing any of the covers. Should it be necessary to operate the unit with the covers off, exercise extreme caution, staying clear of **moving chains** and **live electrical circuits**.

SYMPTOM	CHECK/ADJUST
Shutters do not open completely	Reset shutter position as follows: <ol style="list-style-type: none"> <li>a. Press and hold Preset Switches 1 and 4 (see Figure 4-3-5) until the light in both switches flash ones. This loads an artificial number into the electronic positioning system, enabling shutter movement in both directions.</li> <li>b. Move the shutters out with the individual controls but make certain to release the shutter control switch as soon as the shutter reach its fully open position.</li> <li>c. Repeat this procedure if necessary until all four shutters are returned to their fully open position. Driving the shutters against the stops will produce a rattling sound (cogging). Note that this will not cause any damage if done briefly.</li> <li>d. Press and hold Preset Switches 2 and 3 until the light in both switches flashes ones. This sets the electronic positioning counters to zero. The shutters are now calibrated.</li> </ol> Note: Should the symptom recur, check for malfunctioning step motor driver.
One of the shutters moves in one direction only, regardless of toggle switch direction input.	Step motor driver defective. (Direction input not responding). Replace driver.
One of the shutters moves unevenly and loses position, requiring frequent shutter resets.	One of the step motor drivers is defective. Run one shutter only at a time to determine which shutter is causing the problem. Replace the step motor driver for that shutter.
One of the shutter motors is making a humming or high-pitch noise even when not activated.	Step motor driver defective (switching oscillator frequency off). Replace step motor driver.

### 5.14.1 Replacing PC Boards for Shutter Drive

Three types of PC Boards, as shown in Figure 5-14-a, are directly involved in the shutter drive. They are, the Shutter Switch Board, located in the Shutter Control (1), the Shutter Control Board (2) and the Step Motor Driver Boards (3-6). The Power Supply Board (see Figure 5-3-1) is also involved as it provides power for the transport band drive.

To replace the boards, follow the directions in sections 5.8 and 5.9.

**Note:** If any of the Step Motor Driver Boards are replaced, the DIP switches on the board should be set as shown in Figure 5-14-c.

After board replacement, check and calibrate according to instructions in the Maintenance and Calibration section of this manual.

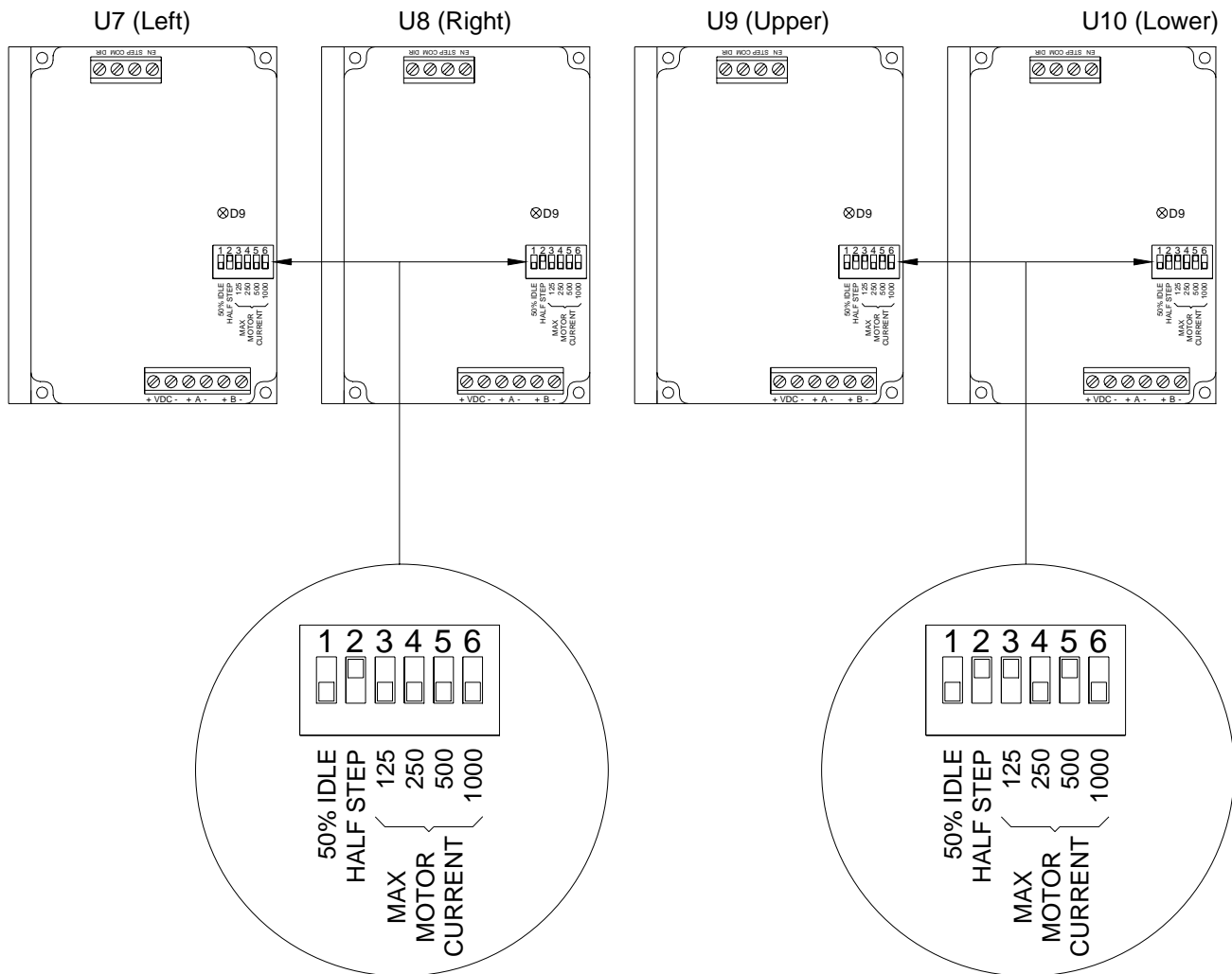

Figure 5-14-c. Setting of DIP Switches on Step Motor Driver Boards

### 5.14.2 Replacing Step Motors

The four step motors, M2, M3, M4 and M5 are mounted to brackets attached to each corner of the light box. See Figure 5-14-b.

The step motors are very reliable and would not be expected to require replacement. If, however, replacement is needed, see Figures 5-14-b and 5-14-c and proceed as follows:

- a. Make certain **power is off** and the **line cord disconnected**.
- b. Remove right, left, back, top front and top covers as described in section 5.2.2.
- c. Follow the instructions in section 5.2.1 and position the cutouts in the transport band in the back of the light box.
- d. **Turn power off.**
- e. Make a sketch and mark the wires connected to the step motor to be replaced.
- f. Disconnect the wires from the terminal board.
- g. Remove the four screws with nut and washer, holding the motor to the bracket.
- h. Lift the timing belt off the pulley and pull the motor out and away from the bracket.
- i. Note the clearance between the pulley and the motor body. Use a 5/64" hex wrench and transfer the pulley to the new motor with the same clearance between the pulley and the motor body.
- j. Install the new motor in reverse order. Before tightening the nuts, move the motor back and forth until the timing belt has the proper tension. Applying a slight pressure to the belt between the two pulleys should cause a deflection of approximately 1/4". Also, check against other motor/timing belts
- k. Make certain that the shutter controlled by the motor replaced is in its fully open position. If not, turn the motor pulley manually.
- l. Restore normal operation by completing the steps in section 5.2.1.
- m. Press and hold Preset Switches 2 and 3 (see Figure 4-3-5) until the light in both switches starts to flash.
- n. Check that the shutter open and closes completely. If needed, follow the check/adjust procedure in the Trouble Shooting section 5.14.

Figure 5-14-c. Step Motor Mounting

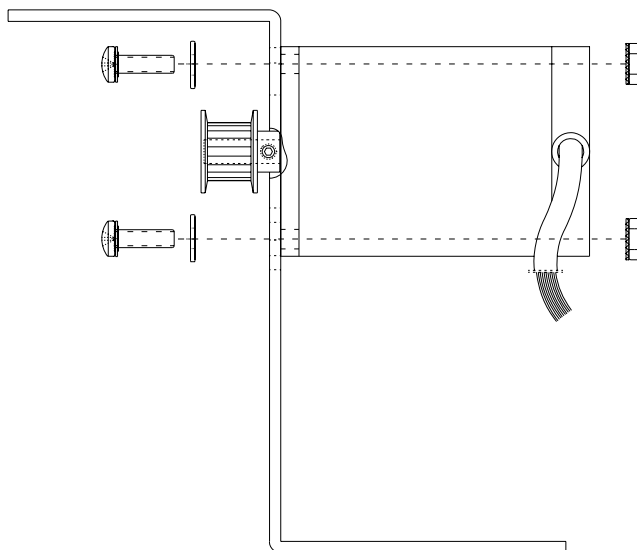

**SECTION 6**  
**SCHEMATICS**

<b>CONTENTS</b>	<b>PAGE</b>
Line Voltage/Power Supply Board .....	6.1
Relay Interface Board and Transport Band Drive .....	6.2
Shutter Control and Switch Boards .....	6.3
Shutter Drive .....	6.4
Light Box .....	6.5
Frame Selector PCB .....	6.6
Relay Interface PCB .....	6.7
Shutter Switch PCB .....	6.8
Shutter Control PCB .....	6.9

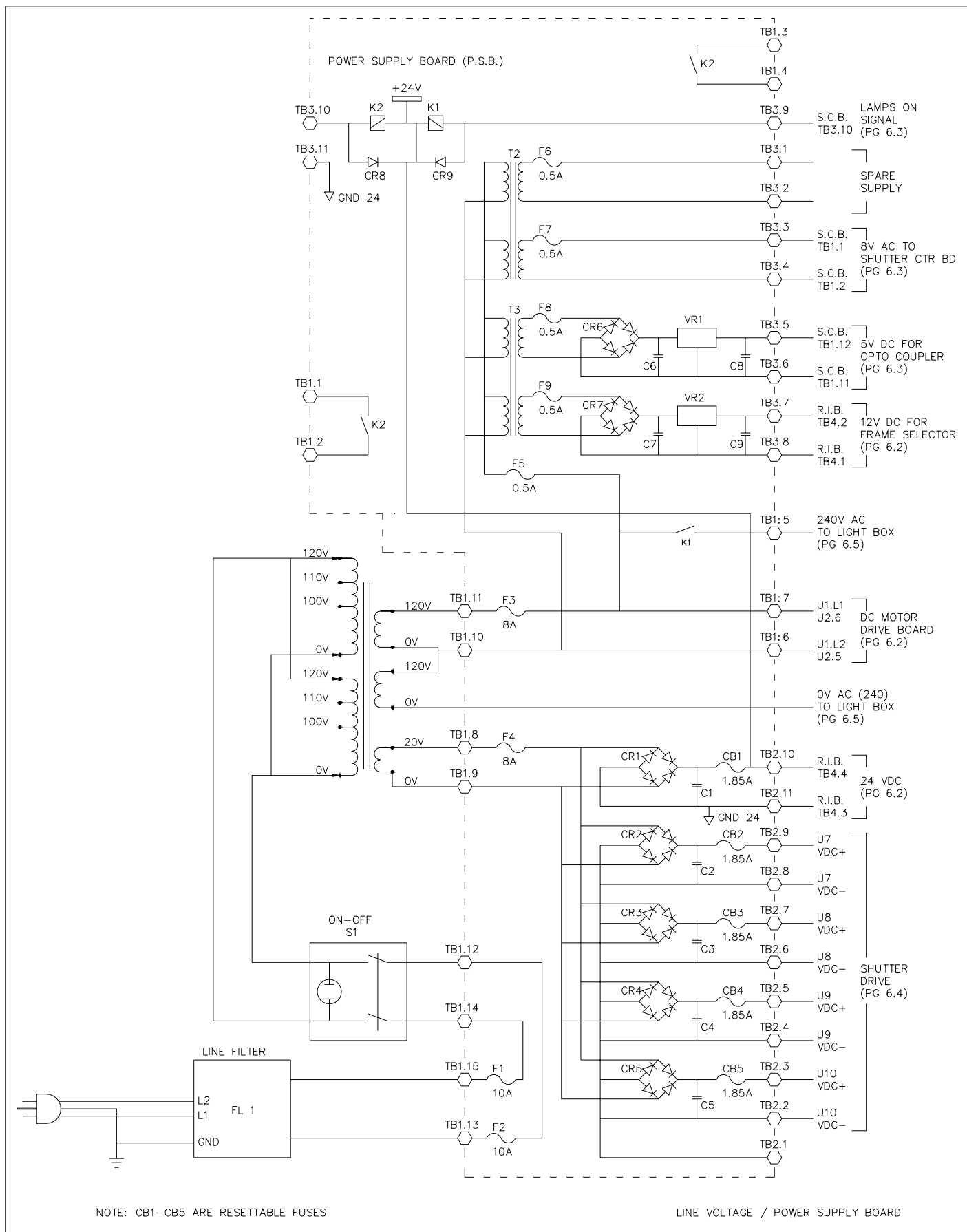

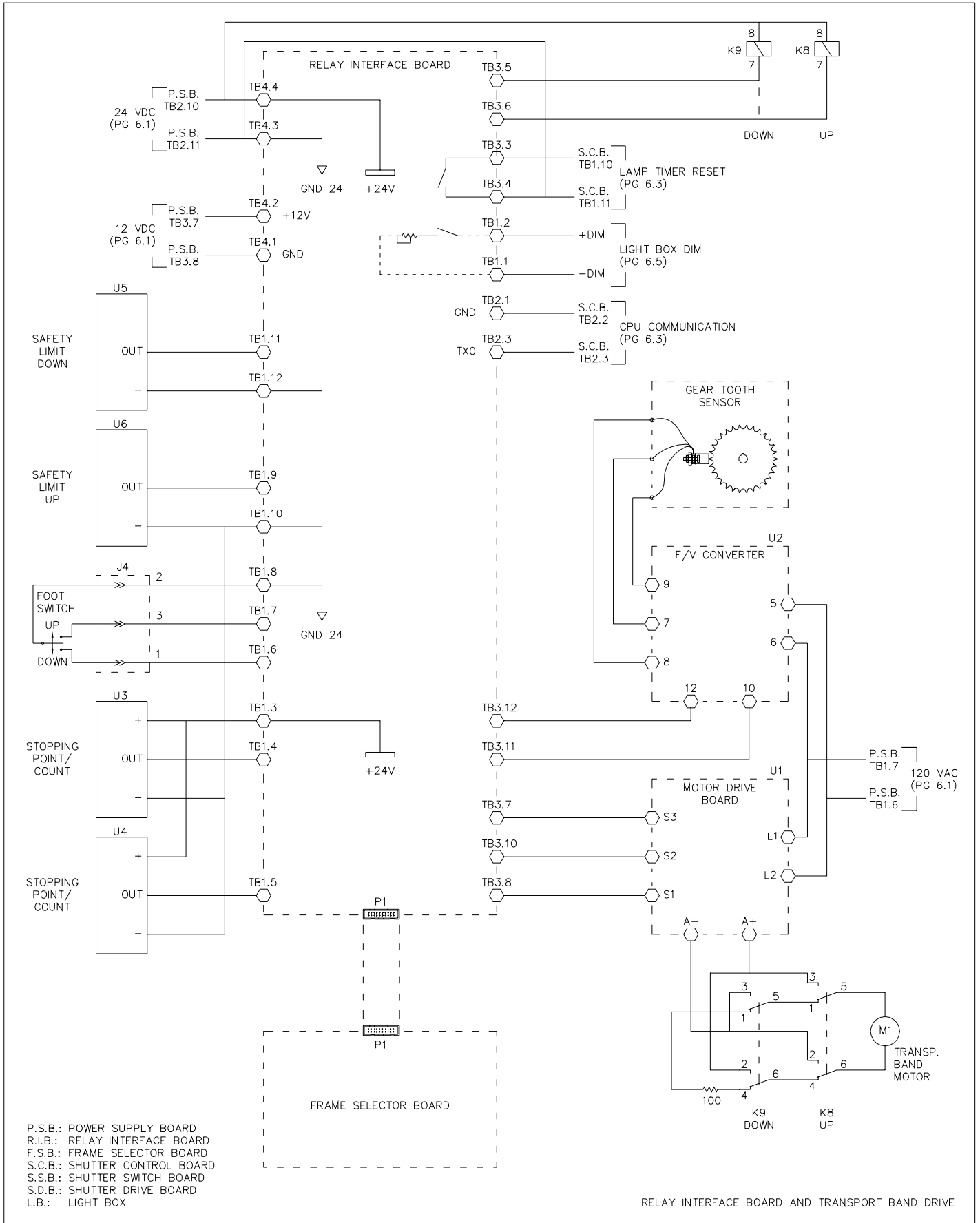

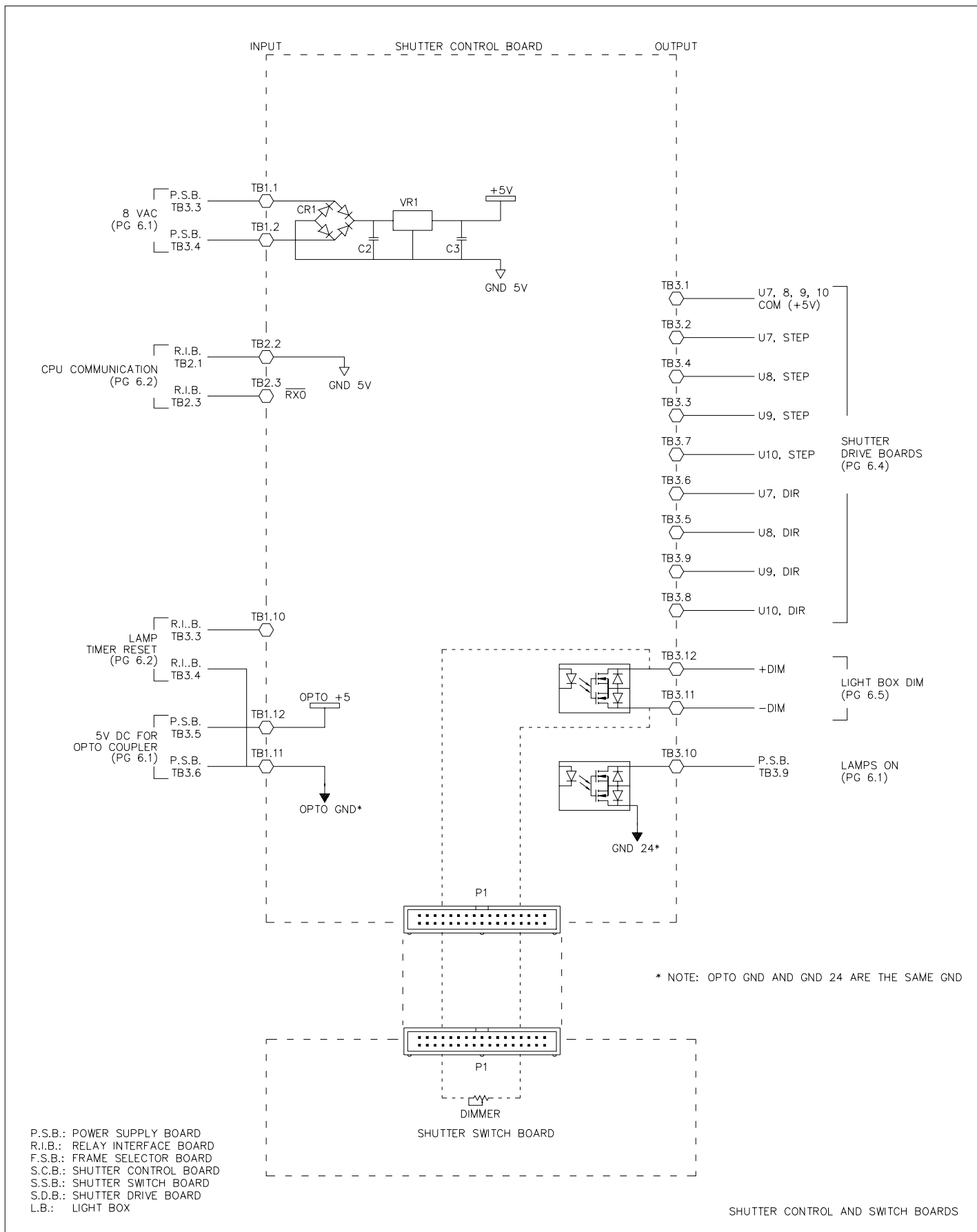

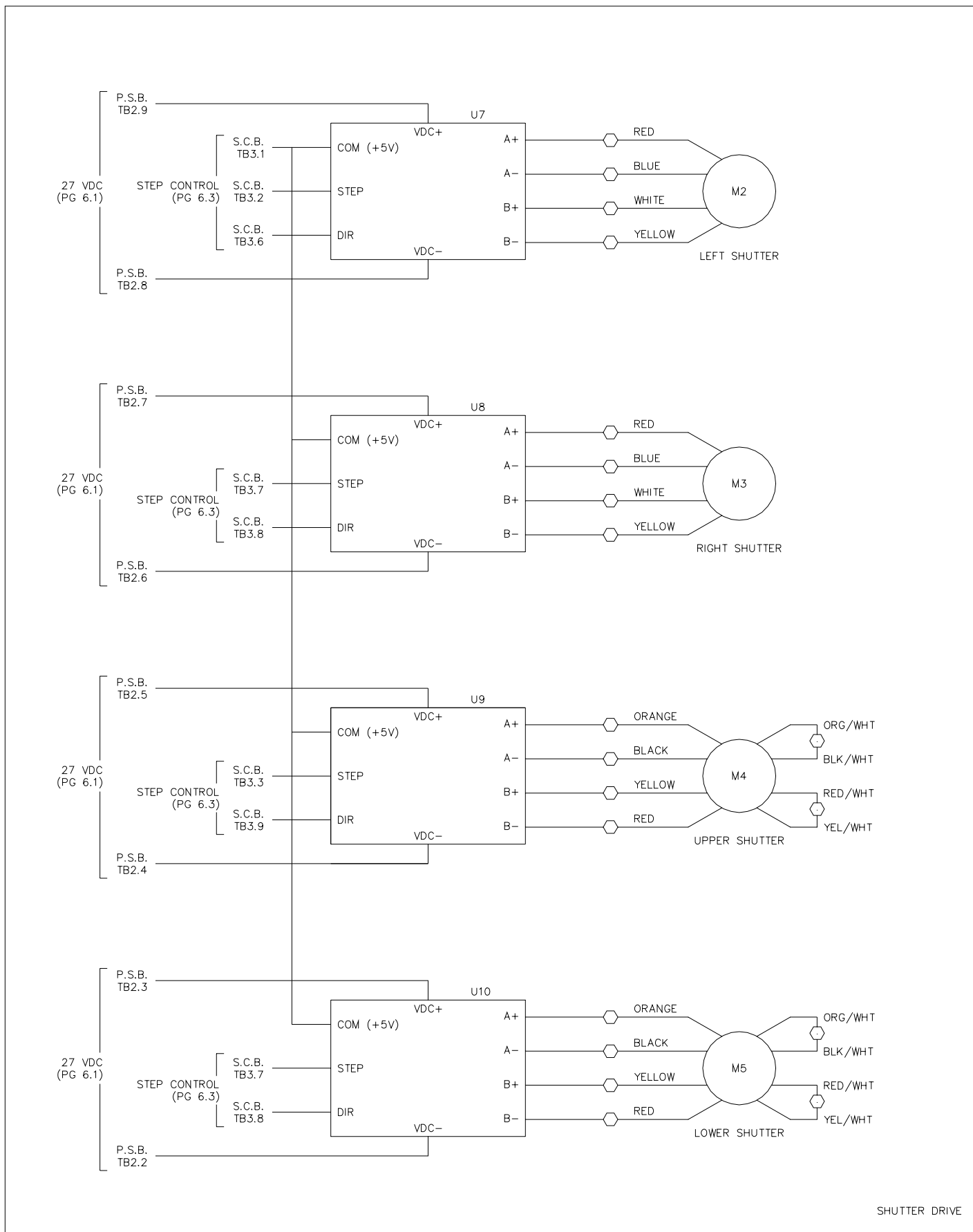

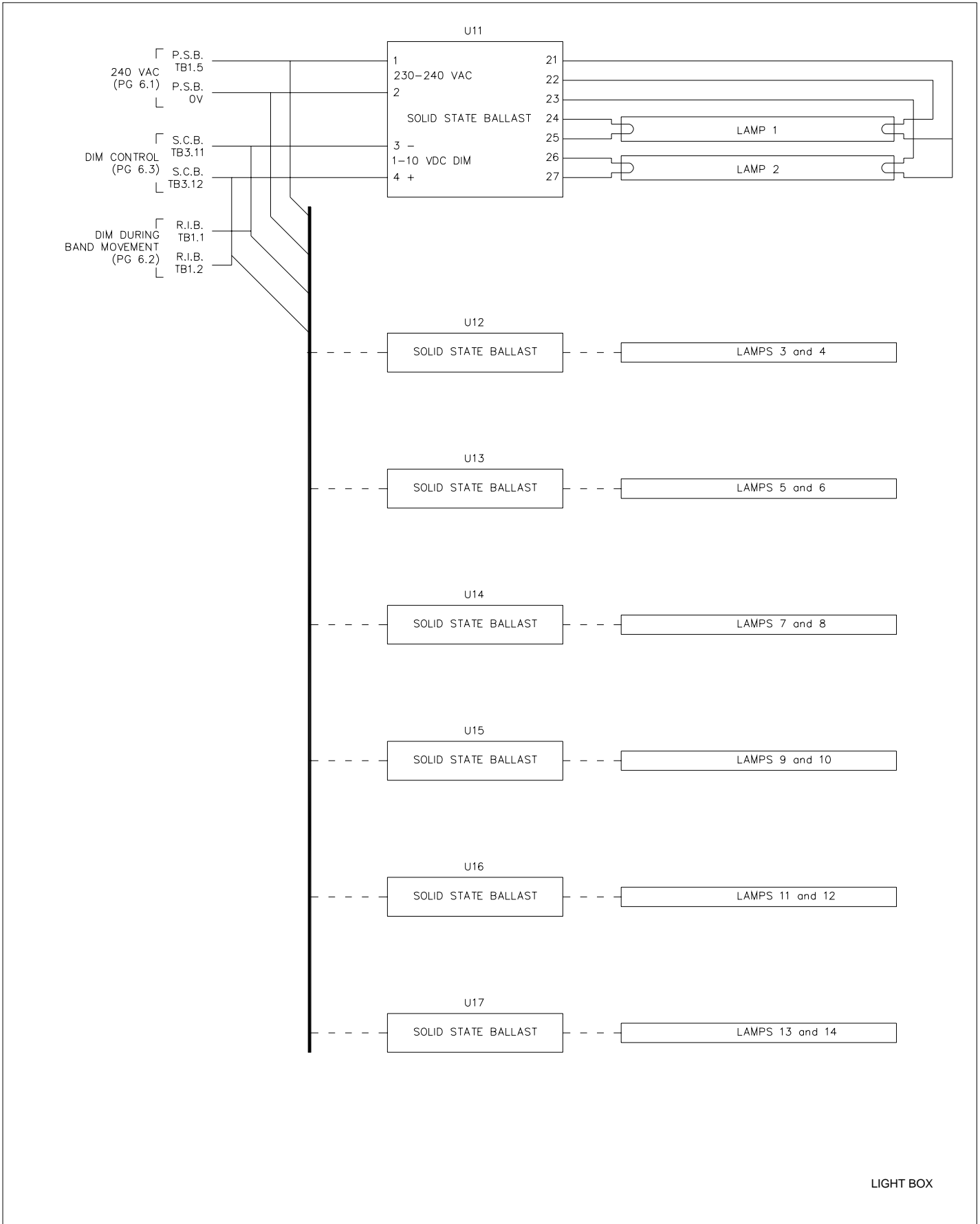

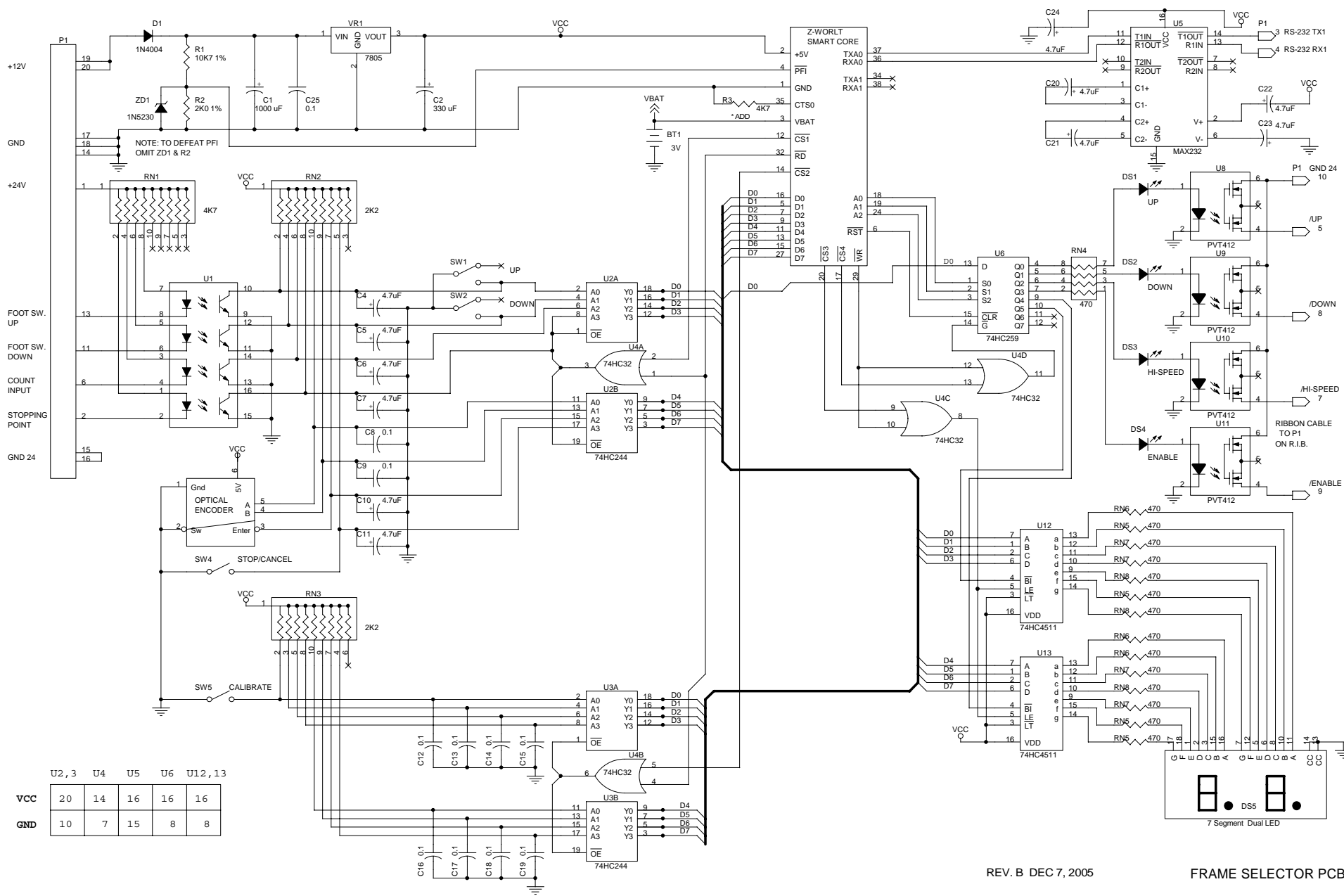

REV. B DEC 7, 2005

FRAME SELECTOR PCB

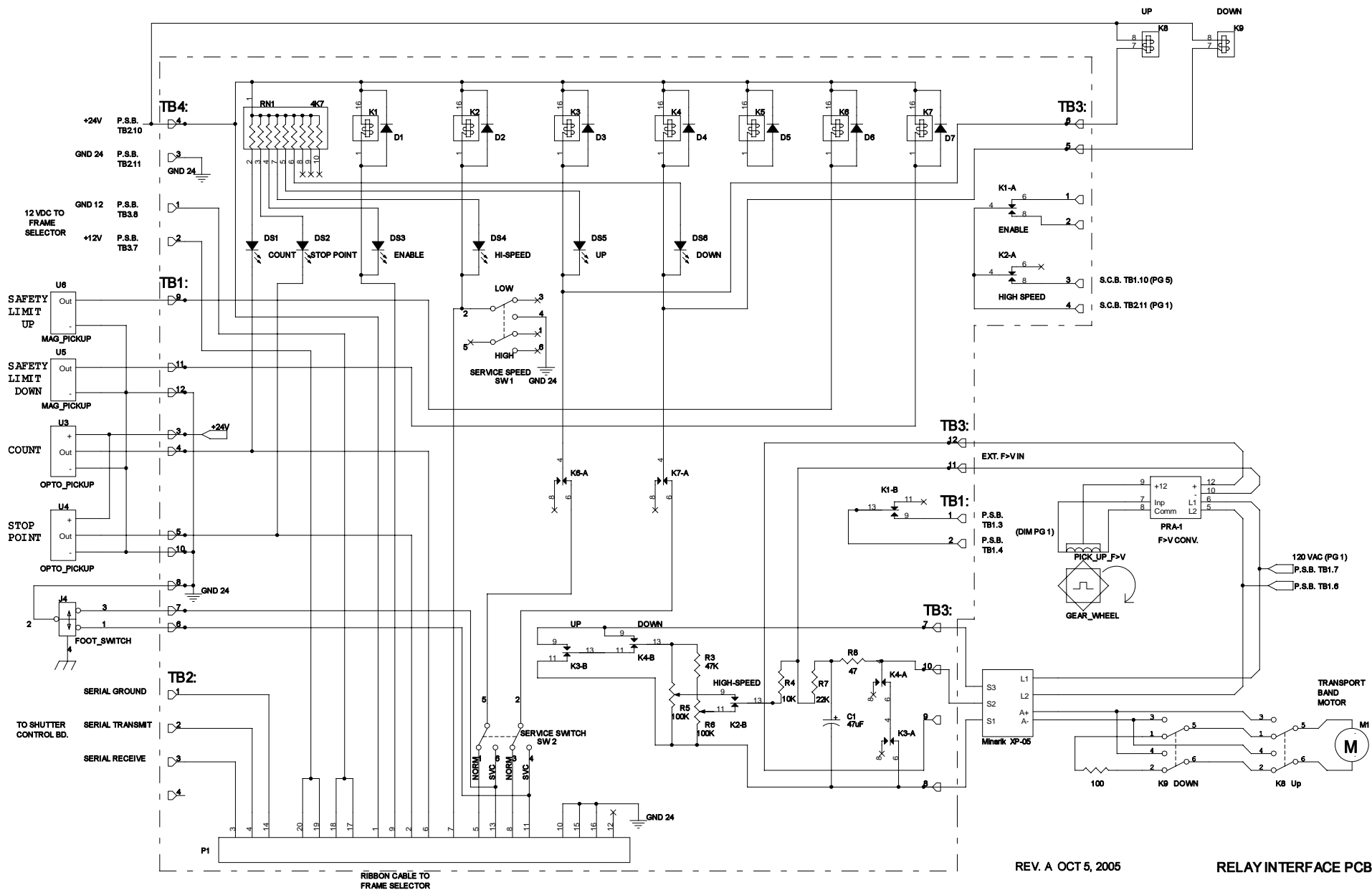

REV. A OCT 5, 2005

RELAY INTERFACE PCB

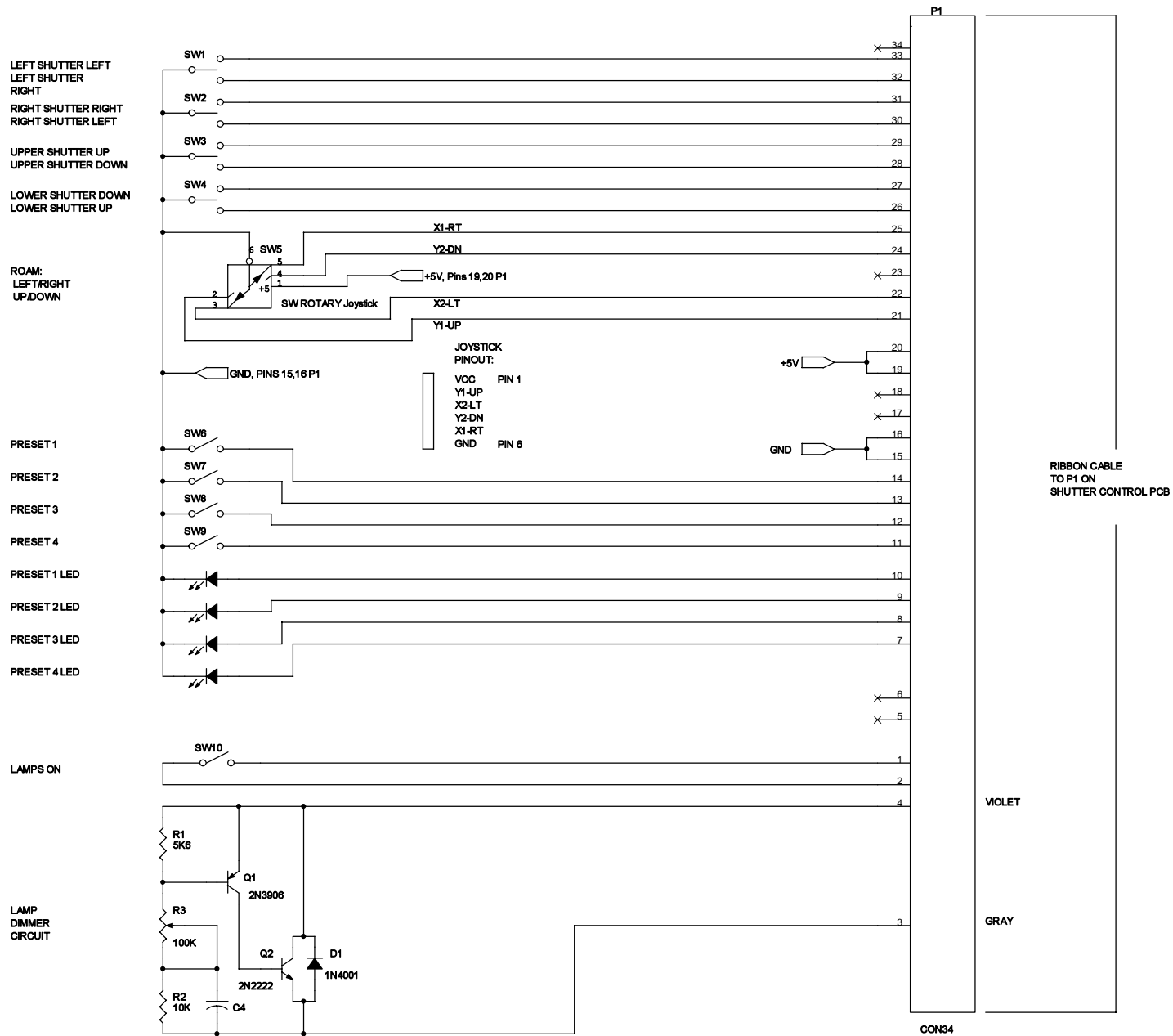

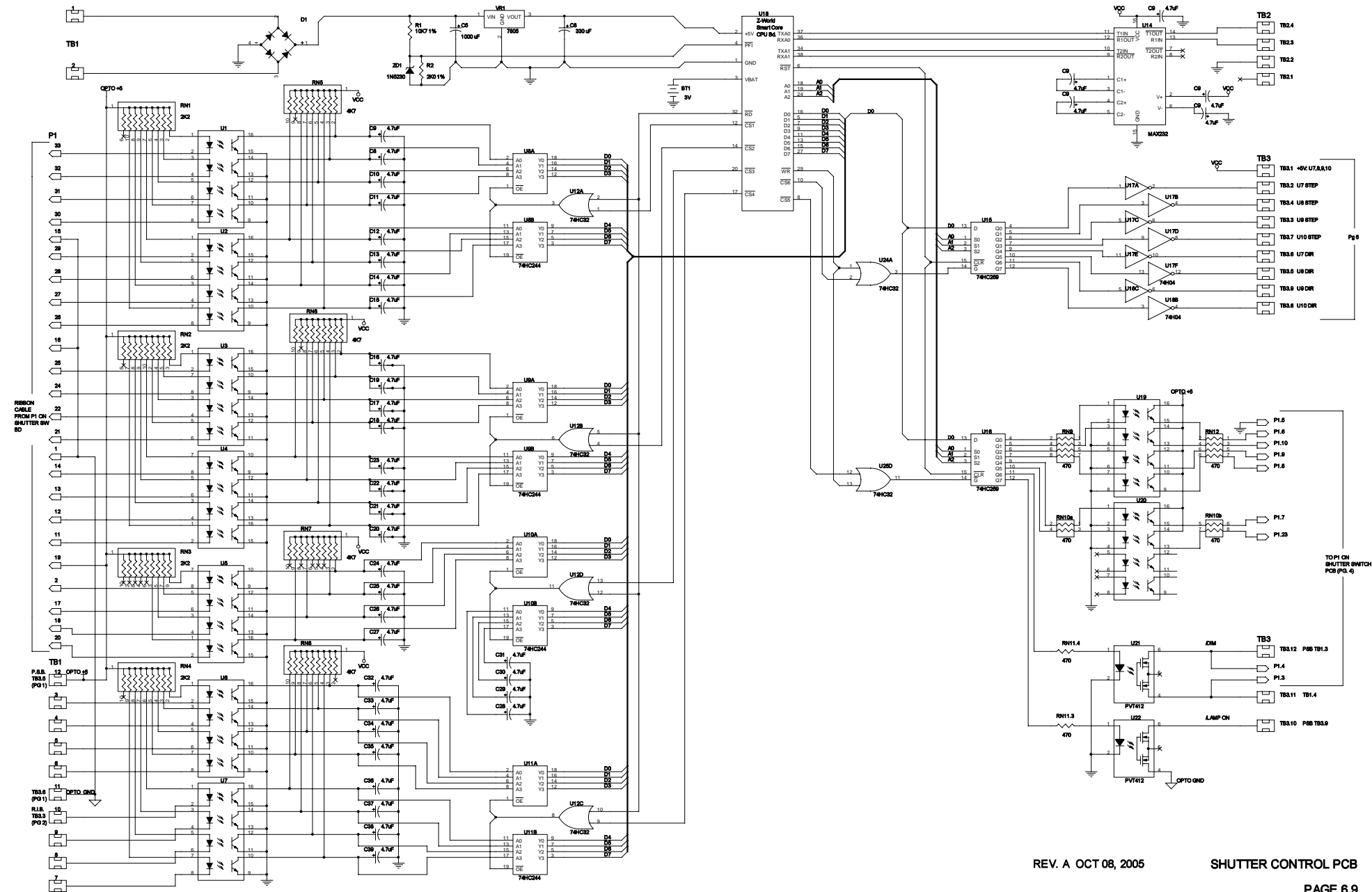

REV. A OCT 08, 2005

SHUTTER CONTROL PCB

**SECTION 7**  
**MAINTENANCE and CALIBRATION**

<b><u>CONTENTS</u></b>	<b><u>PAGE</u></b>
7.1 Introduction .....	7.1
7.2 Transport Band Cleaning .....	7.1
7.3 Viewing Area Cleaning .....	7.1
7.4 Check Decals and Operator Safety Instructions .....	7.2
7.5 Check Resistance from Cabinet to Input Power Connector Pin .....	7.2
7.6 Voltage Measurements .....	7.2
7.7 Check and Adjust Transport Band Speed and Stopping Point .....	7.6
7.8 Check and Adjust Magnetic Sensor .....	7.10
7.9 Check and Adjust Photo Sensors .....	7.12
7.10 Check Frame Selector .....	7.13
7.11 Check and Adjust Shutter System .....	7.13

## 7.1 Introduction

This section covers maintenance, including safety product assurance checks and adjustments to be performed after replacement of certain components and/or as directed in the procedure. Record of the safety product assurance checks is to be recorded on the maintenance schedule in section 8 of this manual.

### WARNING

Read and follow the steps in the Safety Information section of this manual.

### WARNING

Disconnect the power cord before removing any of the covers. Should it be necessary to operate the unit with the covers off, exercise extreme caution, staying clear of **moving chains** and **live electrical circuits**.

### WARNING

Service and calibration of the Rolloscope should only be performed by qualified personnel.

## 7.2 Transport Band Cleaning

### Cleaning by User

The front surface of the transport band is easily cleaned from the front of the Rolloscope. A high quality plastic cleaner, such as "Kleenmaster\* Brillianize", compatible with polyester resin can be used.

\* Kleenmaster is a registered trademark of The Brillianize Company, Benicia, CA 94510.

### Cleaning by Qualified Service Engineer Only

The back of the transport band is not exposed, so it should normally not need cleaning. In case, however, it would need cleaning in certain areas, it must be done from the inside of the Rolloscope. Proceed as follows:

- a. Remove side and back covers according to instructions in section 5.2.2.
- b. Drive transport band so the area to be cleaned is behind the back of the light box.
- c. Turn power off.
- d. Clean the back of the transport band by reaching in from each side in the opening above the upper take-up reel.
- e. Turn power on and go to the next area needed cleaning.
- f. Repeat c, d and e as needed.

## 7.3 Viewing Area Cleaning

The viewing area behind the transport band (the front of the shutter shield) may be cleaned from the front of the Rolloscope. The same kind of cleaner used for the transport band should be used.

Use the cutouts at the end of the transport band (past frame #100) to access the surface of the shutter shield. Proceed as follows:

- a. Follow the instructions in section 5.2.1 and position the cutouts in front of the light box.
- b. Proceed with the cleaning
- c. Restore normal operation by completing the steps in section 5.2.1.

For a more complete cleaning of the viewing area, follow the instructions in sections 5.5 and 5.6 and remove both the shutter shield and the diffuser.

## 7.4 Check Decals and Operator Safety Instructions

Verify that all decals and labels with safety instructions are in place.

## 7.5 Check Resistance from Cabinet to Input Power Connector Pin

With a Digital Multimeter, check that the resistance from any exposed metal point of the cabinet to the power connector ground pin is less than 0.10 ohm.

Make certain to check the resistance of the test leads (normally between 0.10 and 0.20 ohm) and subtract this from the reading obtained during the resistance check.

## 7.6 Voltage Measurements

Voltage measurements are made on three circuit boards, the Power Supply Board (PSB), the Shutter Control Board (SCB) and the Frame Selector Board (FSB). See tables and figures 7-6-a, 7-6-b and 7-6-c.

To gain access to the Power Supply Board and the Shutter Control Board, see section 5.3. For the Frame Selector Board, see section 5.9.

**Note:** If voltage readings are not in the range of the reference, the first step is to check that the line voltage is connected to the correct taps on transformer T1. See section 3 "Installation."

### 7.6 Voltage Measurements, continued

**Note:** All measurements taken with transport band stationary and lamps at maximum intensity.

#### a. Voltage Measurements on Power Supply Board

Description	Measuring Points	Reference
Line voltage	TB1. 13 - 15	100 - 120 VAC (200 - 240)
120 VAC	TB1. 6 - 7	120 ± 6 VAC
+24 V for RIB and FSB	TB2. 12 - 11	27.3 ± 1.5 VDC
+24 V for SDB, left	TB2. 9 - 8	26.9 ± 1.5 VDC
+24 V for SDB, right	TB2. 7 - 6	26.9 ± 1.5 VDC
+24 V for SDB, upper	TB2. 5 - 4	26.9 ± 1.5 VDC
+24 V for SDB, lower	TB2. 3 - 2	26.9 ± 1.5 VDC
+12 V for FSB	TB3. 7 - 8	12.0 ± 0.5 VDC
+5 V for Opto-Coupler	TB3. 5 - 6	5.0 ± 0.25 VDC

FSB = Frame Selector Board  
 RIB = Relay Interface Board

SDB = Shutter Driver Board

Table 7-6-a. Voltage Measurements on Power Supply Board

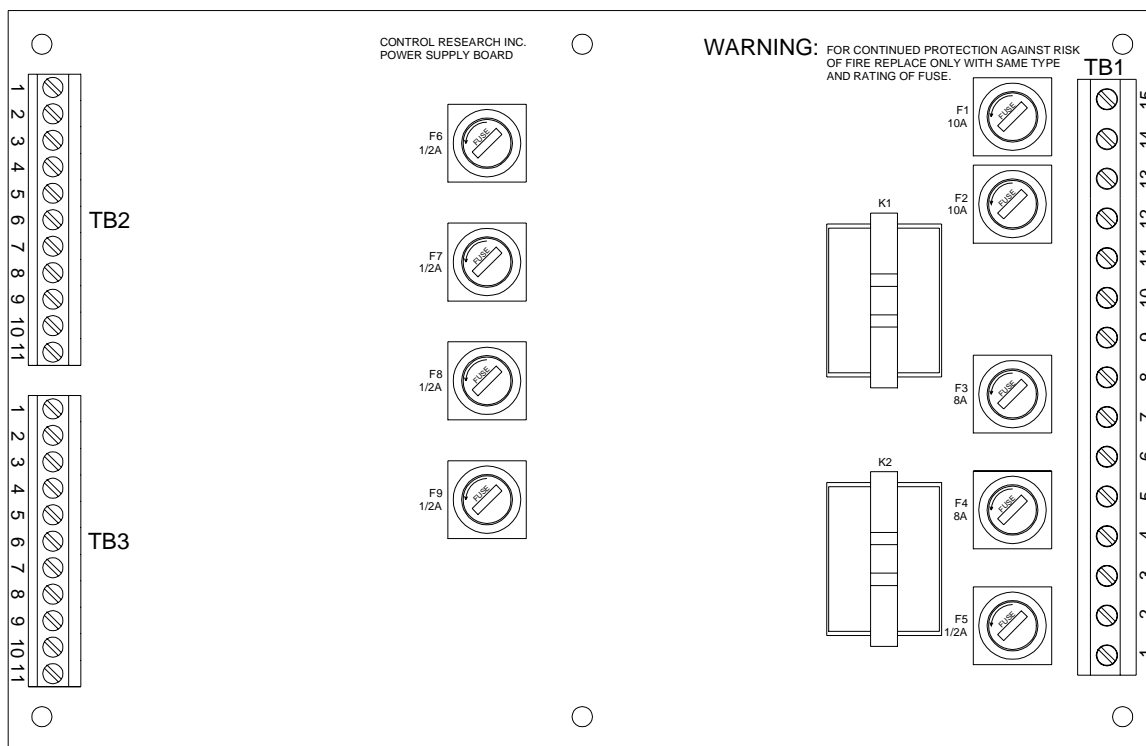

Figure 7-6-a. Power Supply Board

### 7.6 Voltage Measurements, continued

**Note:** All measurements taken with transport band stationary and lamps at maximum intensity.

#### b. Voltage Measurements on Shutter Control Board

Description	Measuring Points	Reference
+5 V for SCB	TP: +5V - GND	5.0 ± 0.25 VDC
3 V Battery for SCB	+ on B1 - GND	3.3 - 1.5 VDC

SCB = Shutter Control Board

Table 7-6-b. Voltage Measurements on Shutter Control Board

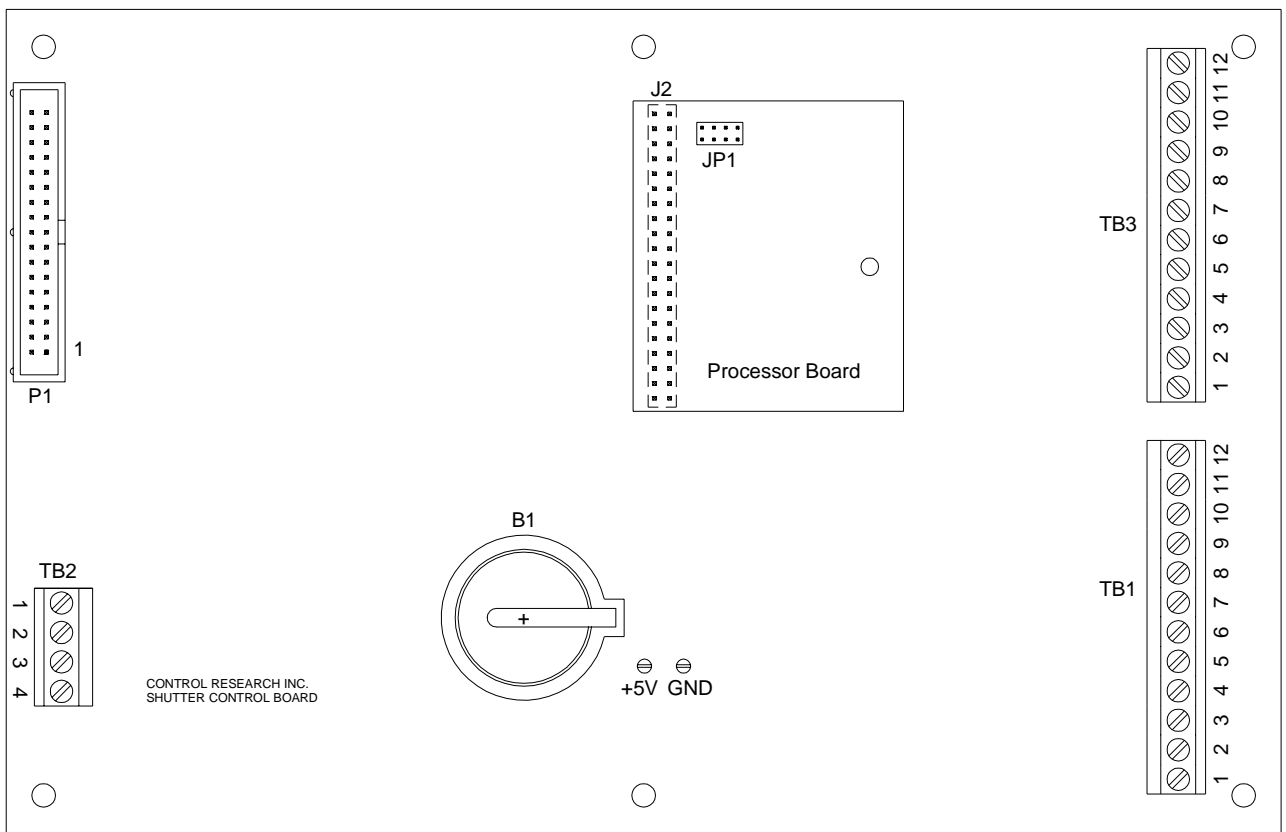

Figure 7-6-b. Shutter Control Board

## 7.6 Voltage Measurements, continued

**Note:** All measurements taken with transport band stationary and lamps at maximum intensity.

### c. Voltage Measurements on Frame Selector Board

Description	Measuring Points	Reference
+5 V for FSB	TP: +5V - GND	$5.0 \pm 0.25$ VDC
3 V Battery for FSB	+ on B1 - GND	1.5 - 3.3 VDC

FSB = Frame Selector Board

Table 7-6-c. Voltage Measurements on Frame Selector Board

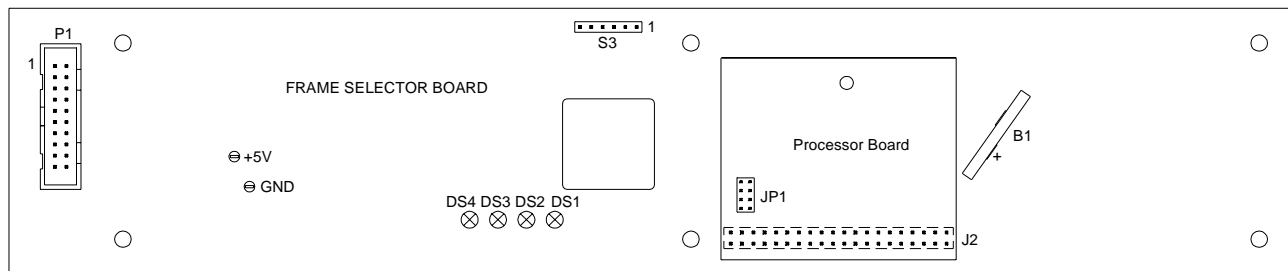

Figure 7-6-c. Frame Selector Board



## 7.7 Check and Adjust Transport Band Speed and Stopping Point, continued

### Adjustments on Motor Drive Board

Remove the Cover for Electronics and the Right Side Cover as directed in Section 5.2.2. See Figure 5-3-1 and locate the Motor Drive Board.

The Motor Drive Board is shown in Figure 7-7-b. There are four trim potentiometers on the board. They are all adjusted at the factory and should normally not have to be readjusted in the field.

If the board is replaced, the trim potentiometers on the new board should be set to the same value as on the old board unless instructions sent with the new board from the Rolloscope manufacturer gives different directions.

To identify the trim potentiometers settings, we use a twelve hour clock.

The factory settings for the trim potentiometers are as follows:

Trim Potentiometer	Setting (O'clock)
MAX SPEED	2:30
ACCEL/DECEL	7:30 (min.)
IR COMP	9:00
CURRENT LIMIT	11:30

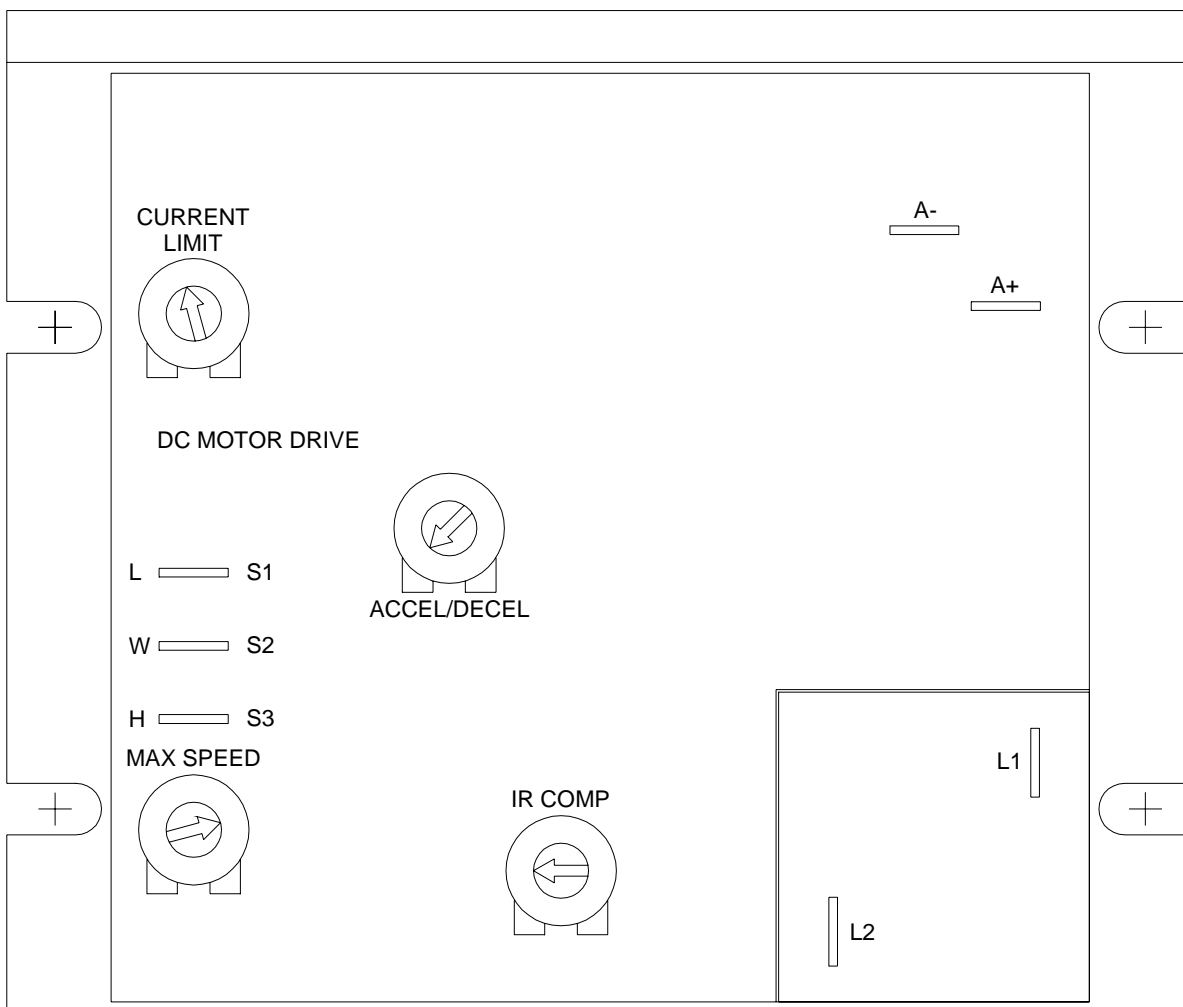

Figure 7-7-b. Motor Drive Board

## 7.7 Check and Adjust Transport Band Speed and Stopping Point, continued

### Adjusting Speed of Transport Band

- Remove the Cover for Electronics and the Right Side Cover as directed in section 5.2.2.
- Make certain that the trim potentiometers on the Motor Drive Board are adjusted as shown in Figure 7-7-b.
- Check that the DIP switches on the Frequency/Voltage Converter are set as shown in Figure 7-7-d. 1 and 3 should be on, 2 and 4 should be off.
- Set the HIGH SPEED potentiometer R5 on the Relay Interface Board shown in Figure 7-7-c to 95%.
- Drive the transport band back and forth between frames 90 and 100 while measuring the voltage at TB3.11-12. See Figure 7-7-c.
- Adjust the RANGE ADJUST trim potentiometer on the Frequency/Voltage Converter, shown in Figure 7-7-d, until the maximum voltage measured is about 9.7 VDC. Note that turning the trim pot CCW increases the voltage.
- Drive the transport band in the down direction from 100 to 90 several times and note the highest reading. It should be between 9.5 and 9.9 VDC.
- Using the frame selector, run the transport band from 0 to 100 and measure the time from start to stop. The time should be 2 min. 32-34 sec. Repeat the procedure from 100 to 0. The time should be the same. If necessary, make small adjustments on the HIGH SPEED potentiometer to bring the time in the range specified.

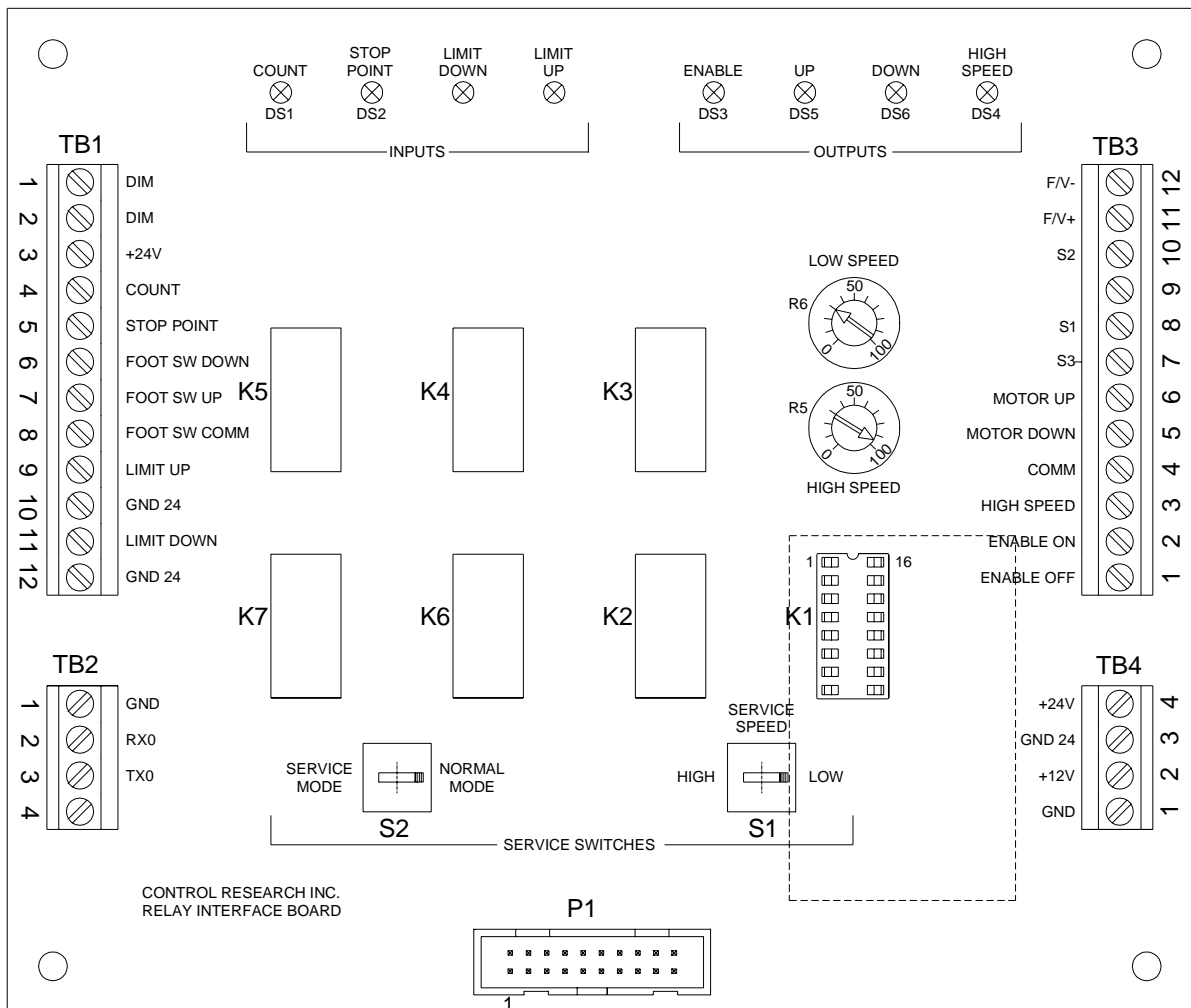

Figure 7-7-c. Relay Interface Board

## 7.7 Check and Adjust Transport Band Speed and Stopping Point, continued

### Adjusting Stopping Point of Transport Band

As mentioned in the Principle of Operation in section 5.13, the black labels along the sides of the transport band activate the photo sensors. In Normal Mode, the labels on the left side keeps track of the frame count while the right side labels are used to determine the stopping point. In High Film Clip Mode the functions are reversed.

To adjust the stopping point, proceed as follows:

- Remove the Cover for Electronics as directed in section 5.2.2.
- Make certain that the speed of the transport band has been set.
- Make certain that Normal Mode is selected.
- Choose a frame about 10 frames from the end of the band (for example 10 or 90) and approach it from both directions using NEXT UP and NEXT DOWN switches.
- If the two stopping points are overlapping, reduce the setting of the LOW SPEED potentiometer R6 on the Relay Interface Board shown in Figure 7.7.c.
- If the stopping points are apart from each other, increase the setting of the LOW SPEED potentiometer R6.

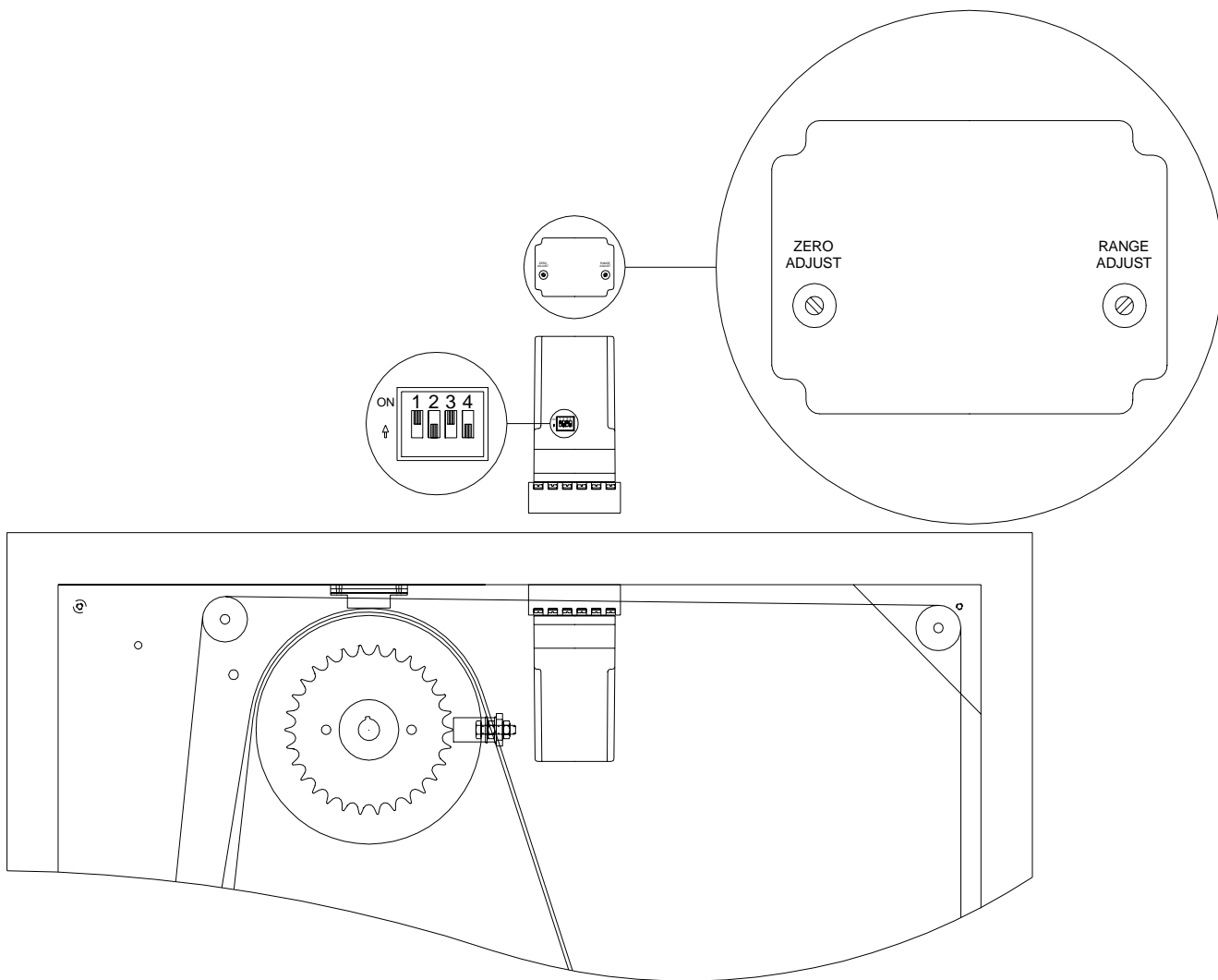

Figure 7-7-d. Adjustments on Frequency/Voltage Converter

## 7.8 Check and Adjust Magnetic Sensors

### WARNING

During this test it is necessary to operate the Rolloscope with the covers off. Exercise extreme caution, staying clear of **moving chains and live electrical circuits.**

As an added security, to make certain the band will not go past its end position, two Magnetic Sensors are used. The Magnetic Sensors will be activated only if the Photo Sensors fail.

The right side magnetic sensor is for the up movement and the left side is for the down movement.

### Preparations

- See section 5.2.2 and remove Cover for Electronics, Top Cover, Right Side Cover and Left Side Cover.
- See Figure 5-2-f and set S1 to HIGH speed and S2 to SERVICE MODE.
- Connect the Transport Band Foot Switch, shown in Figure 5-2-a.

### Checking the Right Side Magnetic Sensor

- a. Turn power on.
- b. Use the foot switch and drive the band up past frame 100 until the steel shims are close to the magnetic sensor on the right side.
- c. Continue to drive the band up and make certain that the magnetic sensor is activated by the steel shims and that the band stops.
- d. With the foot switch, drive the transport band down a couple of feet.
- e. Drive the transport band up again and make certain that the magnetic sensor is activated and the band will stop.
- f. Repeat steps d and e several times. If the magnetic sensor fails to stop the band at any time, go to "Adjusting Magnetic Sensor."

### Checking the Left Side Magnetic Sensor

- a. Turn power on.
- b. Use the foot switch and drive the transport band down and past frame 0 until the steel shims are close to the magnetic sensor on the left side.
- c. Continue to drive the band down and make certain that the magnetic sensor is activated by the steel shims and that the band stops.
- d. With the foot switch, drive the transport band up a couple of feet.
- e. Drive the transport band down again and make certain that the magnetic sensor is activated and the band will stop.
- f. Repeat steps d and e several times. If the magnetic sensor fails to stop the band at any time, go to "Adjusting Magnetic Sensor."
- g. See Figure 5-2-f and set S1 to LOW speed and S2 to NORMAL MODE.

### Adjusting the Magnetic Sensor

- a. Follow steps a - d in the checking procedure and stop the band when the steel shims are below the magnetic sensor.
- b. **Turn power off.**
- c. See Figure 7-8-a and check that the AIR GAP is about 0.1 inches (2.5 mm). If the AIR GAP is more than 0.1 inches, bend the bracket gently and recheck the AIR GAP.
- d. Also, check that all three steel shims are in the correct place and properly secured to the transport band.

If, after making proper adjustment, the magnetic sensor still is not stopping the transport band, check the sensor itself and the associated circuits. The sensor is a normally open Reed Switch and can be checked by an ohm meter. With power turned off, connect the ohm meter to the sensors leads and place a steel object directly on the surface facing the transport band. The contact should now be closed.

### 7.8 Check and Adjust Magnetic Sensors, continued

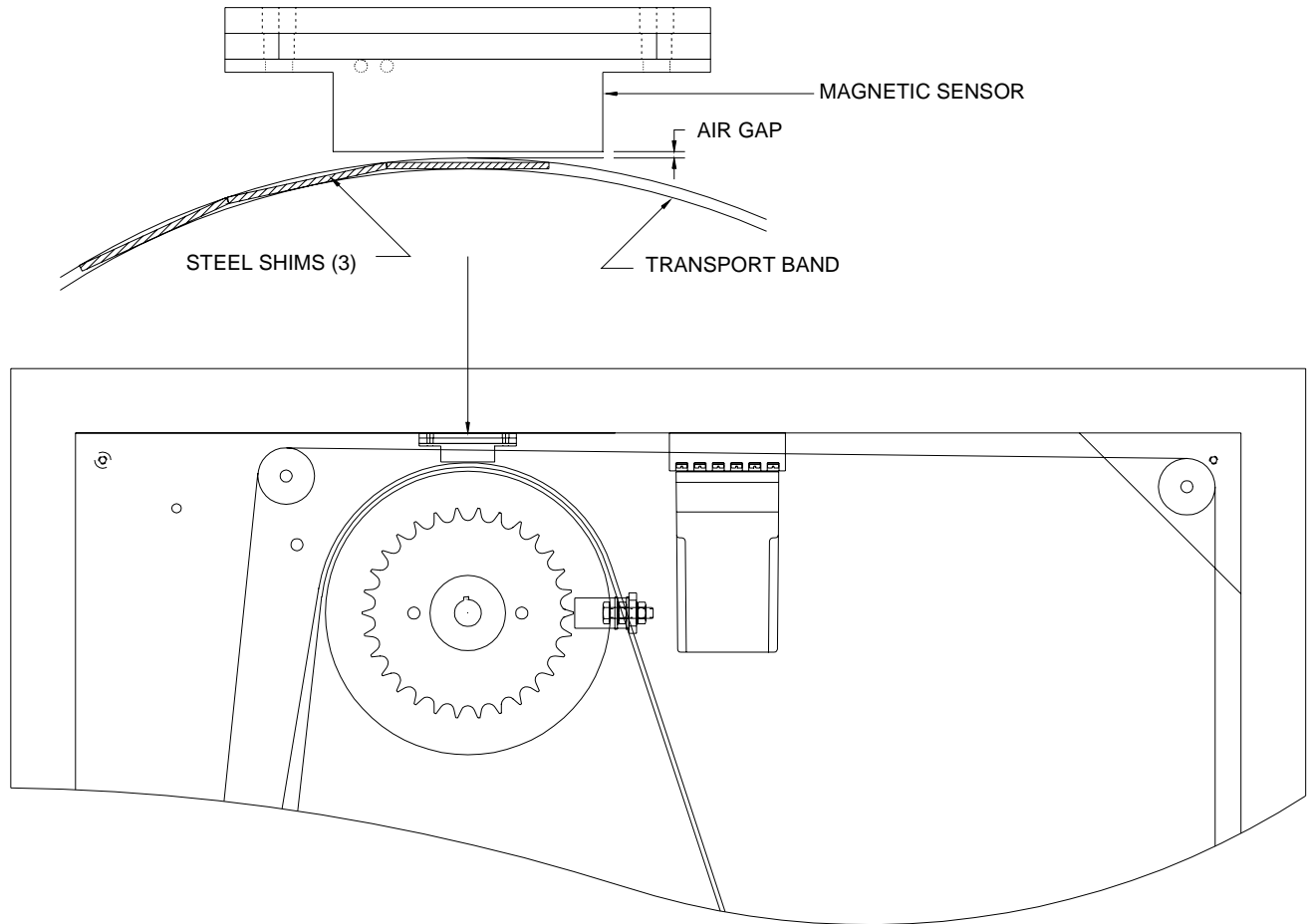

Figure 7-8-a. Checking and Adjusting the Magnetic Sensor

## 7.9 Check and Adjust Photo Sensors

### WARNING

During this test it is necessary to operate the Rolloscope with the covers off. Exercise extreme caution, staying clear of **moving chains and live electrical circuits.**

There are two photo sensors used to keep track of the frame count and to stop the transport band in the correct position. The location of the photo sensors is shown in Figure 5-13-a.

Each photo sensor consists of two parts, the emitter and the receiver. The transport band is passing between the emitter and the receiver where black labels along the edge of the band will interrupt the photo sensor beam, sending a signal to the Rolloscope control.

It is important that the band with its labels is correctly aligned with the beam of the photo sensor. This is shown in Figure 7-9-a. To check this, proceed as follows:

- See section 5.2.2 and remove Left Side Cover, Right Side Cover and both Back Covers.
- Drive the band from 0 to 100 and confirm that all black labels are in place.
- Stop at several places and confirm that the center of the photo sensor beam is aligned with the center of the black label as shown in Figure 7-9-a.
- The position of the photo sensors has been adjusted at the factory and should not have to be changed.
- If there are problems with alignment from one end of the band to the other (band "walking" from side to side), it is most likely caused by a misalignment of the band itself. The adjustment for this is rather complicated and involves not only the take-up reels and supporting rollers, but also the elastic bands. Should this adjustment be required, consult with a factory representative.

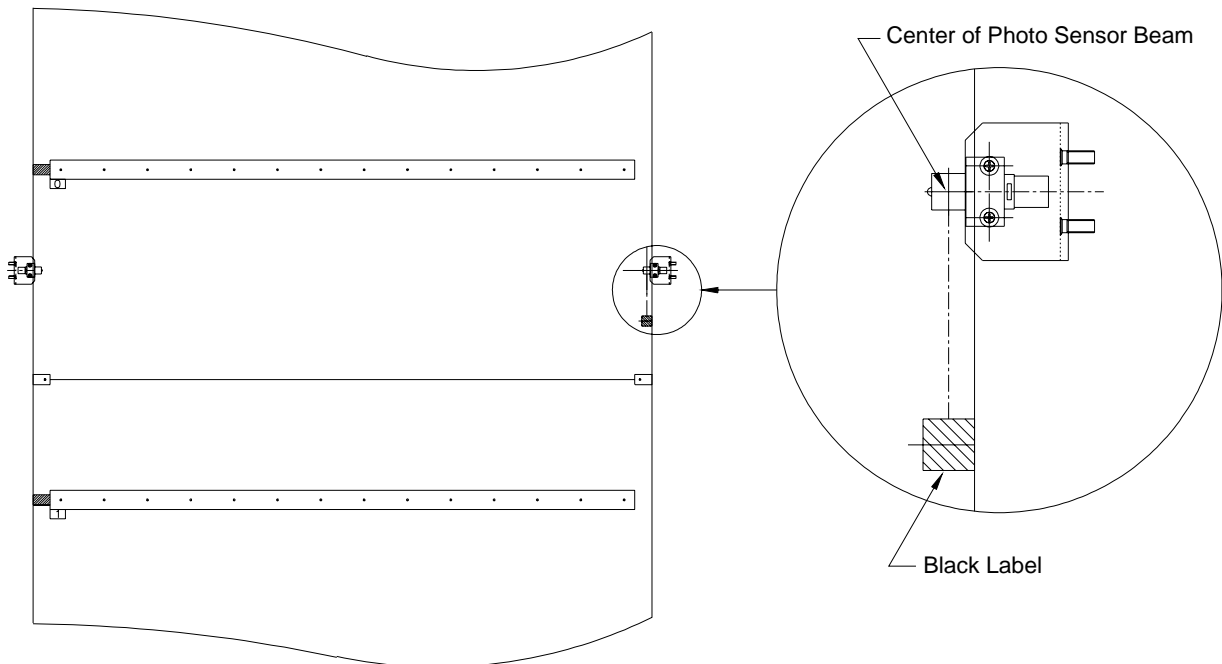

Figure 7-9-a. Alignment of Photo Sensors

## 7.10 Check Frame Selector

To check the operation of the frame selector, see the operating section in this manual and proceed as follows:

- a. Select Normal Mode (film holder in the center of the viewing area).
- b. Select at least 20 different frame numbers at random. Check for correct movement and that the frame number corresponds to the display.
- c. Select every five frames (5, 10, 15...) Up to 100 and back to 0. Check for correct function.
- d. Press STOP while the transport band is moving. Check that it stops normally and retains correct frame number.
- e. With the transport band running, load a new number. Check that it goes to the new number and retains the correct frame number.
- f. Test the function of NEXT UP and NEXT DOWN switches at least 20 times, both single stepping and by holding them down. Check that it stops normally and retains correct frame number.
- g. Single step through all positions (0 to 100) and check stopping position in each frame. Repeat procedure from 100 to 0. Check that the stopping point variation is less than 1/4".

## 7.11 Check and Adjust Shutter System

### Checking Shutter System

See OPERATION section of this manual and check the following:

- a. Operate one shutter at a time and verify that it opens fully and closes down to about 3 inches. Do several instant reversals and verify there is no "Cogging" (rattling sound accompanied by shift in zero position).
- b. Store a different field in each of the PRESETS 1, 2, 3 and 4 and confirm that each of the fields can be recalled at any time and in any frame.
- c. Check if the shutters are in AUTO MODE ON or AUTO MODE OFF. In AUTO MODE ON, the shutter position in each frame number is automatically memorized. For a description of AUTO MODE, see "Shutter Control" in the Operation section of this manual.
- d. Set AUTO MODE ON. Verify proper function by setting all four shutters to any position (except fully open). Move to the next frame and check that the shutters change position. Return to the previous frame and verify that the shutters return to the position you had set.
- e. If found in AUTO MODE OFF, make certain the customer wants it in this mode, before changing it.
- f. Set a small field and test the ROAM control, horizontally, vertically and diagonally.

### Adjusting Shutter System

If the shutters, during the previous test, do not open or close correctly, it will be necessary to do a reset procedure as follows:

- a. Press and hold Preset Switches 1 and 4 (see Figure 4-3-5) until the light in both switches flash ones. This loads an artificial number into the electronic positioning system, enabling shutter movement in both directions.
- b. Move the shutters out with the individual controls but make certain to release the shutter control switch as soon as the shutter reach its fully open position.
- c. Repeat this procedure if necessary until all four shutters are returned to their fully open position. Driving the shutters against the stops will produce a rattling sound (cogging). Note that this will not cause any damage if done briefly.
- d. Press and hold Preset Switches 2 and 3 until the light in both switches flashes ones. This sets the electronic positioning counters to zero. The shutters are now calibrated.

Note: Should the symptom recur, check for a malfunctioning step motor drive or misadjustment causing excessive friction in the shutter movement.



**SECTION 9**  
**PARTS LIST**

<b>CONTENTS</b>	<b>PAGE</b>
9.1 Ordering Information .....	9.1
9.2 Cabinet .....	9.2
9.3 Illuminator .....	9.3
9.4 Electronic Chassis Assembly .....	9.4
9.5 Control Panel .....	9.5
9.6 Auxiliary Panel .....	9.6
9.7 Transport Band Control Components .....	9.7
9.8 Transport Band Components .....	9.8
9.9 Shutter Drive Components .....	9.9
9.10 Line Connection Components .....	9.10
9.11 Bearings .....	9.11

## 9.1 Ordering Information

To order a replacement part, send order to or call your authorized Sales/Service office.

Specify the following information:

1. Model number and complete serial number of the Rolloscope.
2. Control Research, Inc. part number.
3. Description.

To order part not listed, give a complete description of the part and include its function and location.

Please note that service should be carried out by qualified personnel only. Replacement of parts may require re-calibration. See sections 7 of this manual.

## 9.2 Cabinet

ITEM NO.	DESCRIPTION	QTY	PART NUMBER		COMMENTS
			MD	MP	
1	Side Cover	2	S-148-09-010	S-148-09-009	
2	Caster, 3"Wheels w. Circaxle	4	S-121-01-026	S-121-01-026	
3	Front Cover	1	S-121-09-011	S-148-09-011	
4	Table Assembly	1	A-151-10-001	A-150-10-001	Complete with brackets
5	Back Cover	2	S-151-09-009	S-148-09-009	
6	Cover for Electronics	1	S-121-09-017	S-150-09-017	
7	Top Cover	1	S-121-09-012	S-148-09-012	

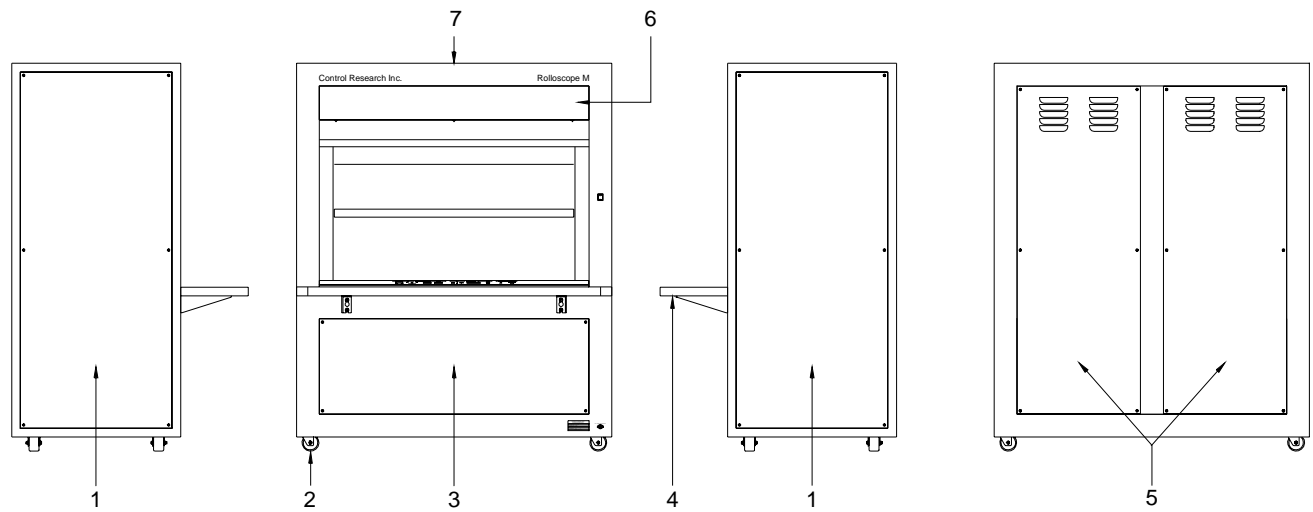

Figure 9-2-a

### 9.3 Illuminator

ITEM NO.	DESCRIPTION	QTY	PART NUMBER		COMMENTS
			MD	MP	
1	Shutter Shield, Acrylic Clear	1	S-151-02-034	S-148-02-034	
2	Lamp, Fluorescent	14	S-121-02-067	S-150-02-067	
3	Diffuser, Acrylic	1	S-151-01-005	S-148-01-005	
4	Ballast, Dimming	5	S-121-02-066	S-150-02-066	
5	Lamp Holder, with metal spring	28	S-121-02-037	S-121-02-037	

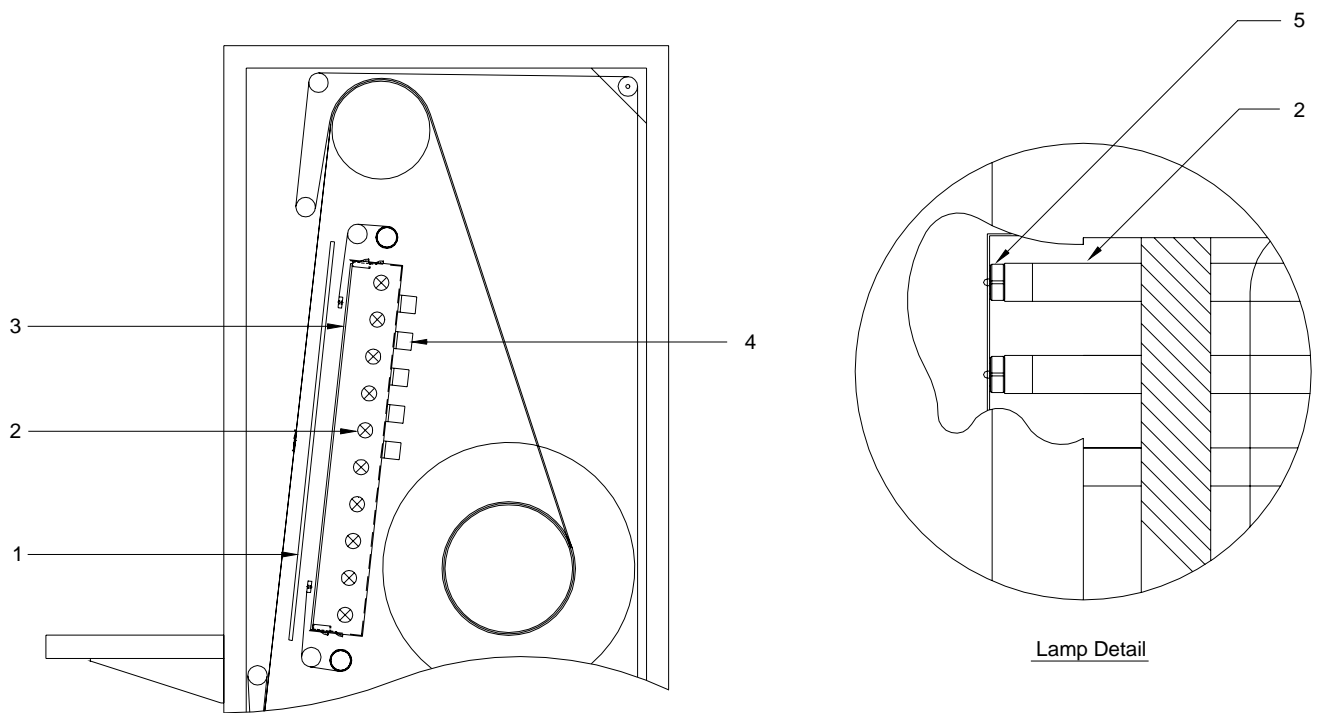

Figure 9-3-a

### 9.4 Electronic Chassis Assembly

ITEM NO.	DESCRIPTION	QTY	PART NUMBER		COMMENTS
			MD	MP	
1a	Shutter Control Board without CPU Board	1	S-121-13-006	S-121-13-006	
1b	CPU Board for Shutter Control Board	1	S-151-13-018	S-148-13-018	
1c	Battery, Lithium 3V	1	S-121-13-021	S-121-13-021	Type BR2325
2	Step Motor Driver	4	S-121-13-003	S-121-13-003	
3	Relay Interface Board	1	S-121-13-004	S-121-13-004	
4	Power Supply Board	1	S-121-13-005	S-121-13-005	
5	DC Motor Drive Board	1	S-121-13-007	S-121-13-007	
6a	Relay DPDT, 24 V	2	S-121-13-008	S-121-13-008	
6b	Relay Socket	2	S-121-13-009	S-121-13-009	
6c	Hold Down Spring for Relay	2	S-121-13-010	S-121-13-010	

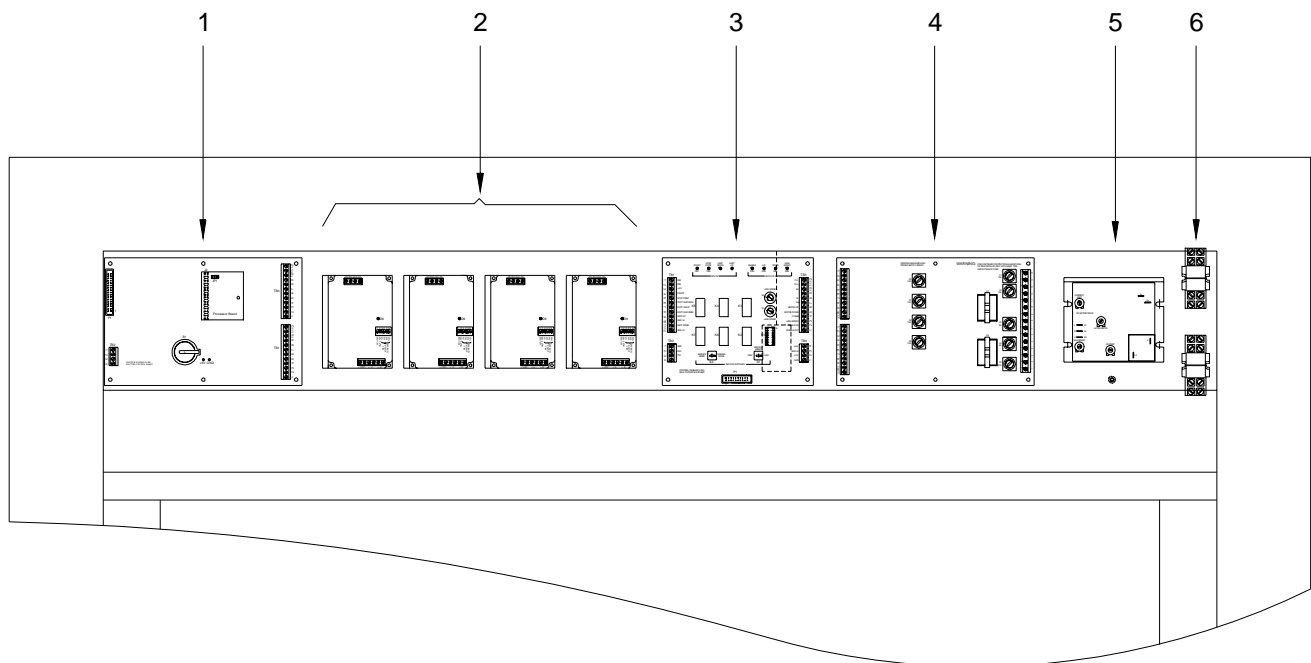
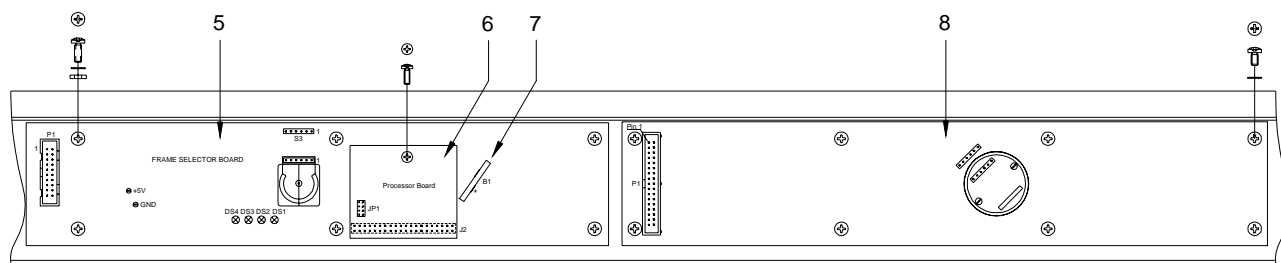

Figure 9-4-a

### 9.5 Control Panel

ITEM NO.	DESCRIPTION	QTY	PART NUMBER		COMMENTS
			MD	MP	
1	Control Panel Assembly	1	A-151-16-001	A-148-16-001	Includes items 2-10
2	Flexible Cable Assembly	2	S-121-16-013	S-121-16-013	
3	Rotary Encoder	1	S-121-16-010	S-121-16-010	
4	Knob for Frame Selector	1	S-121-16-007	S-121-16-007	
5	Frame Selector Board, without CPU Board	1	S-121-16-005	S-121-16-005	
6	CPU Board, for Frame Selector Board	1	S-151-16-014	S-151-16-014	
7	Battery, Lithium 3V	1	S-121-16-021	S-121-16-021	Type BR2325, Tab Mount
8	Shutter Switch Board	1	S-121-16-006	S-121-16-006	
9	Knob for Dimmer	1	S-121-16-008		
10	Shutter Joy Stick	1	S-121-16-009	S-121-16-009	



Back View

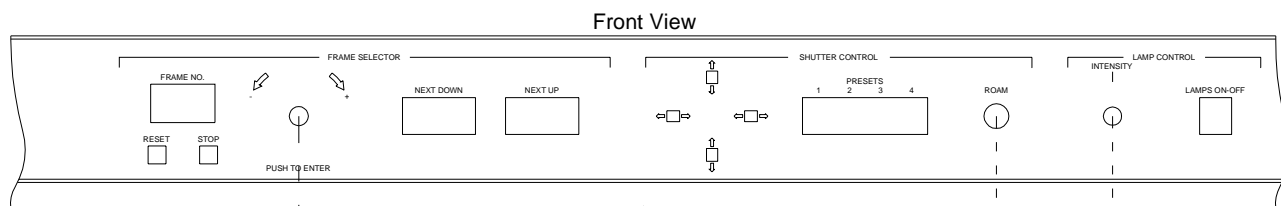

Front View

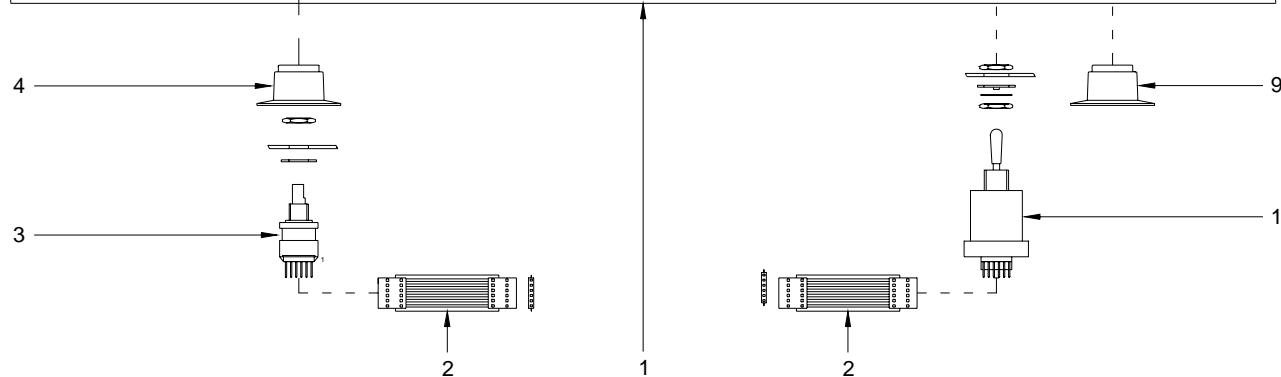

Figure 9-5-a

## 9.6 Auxiliary Panel

ITEM NO.	DESCRIPTION	QTY	PART NUMBER		COMMENTS
			MD	MP	
1	Socket Connector	2	S-121-01-024	S-121-01-024	
2	Optional Foot Switch for Transport band, Complete	1	A-121-22-001	A-121-22-001	

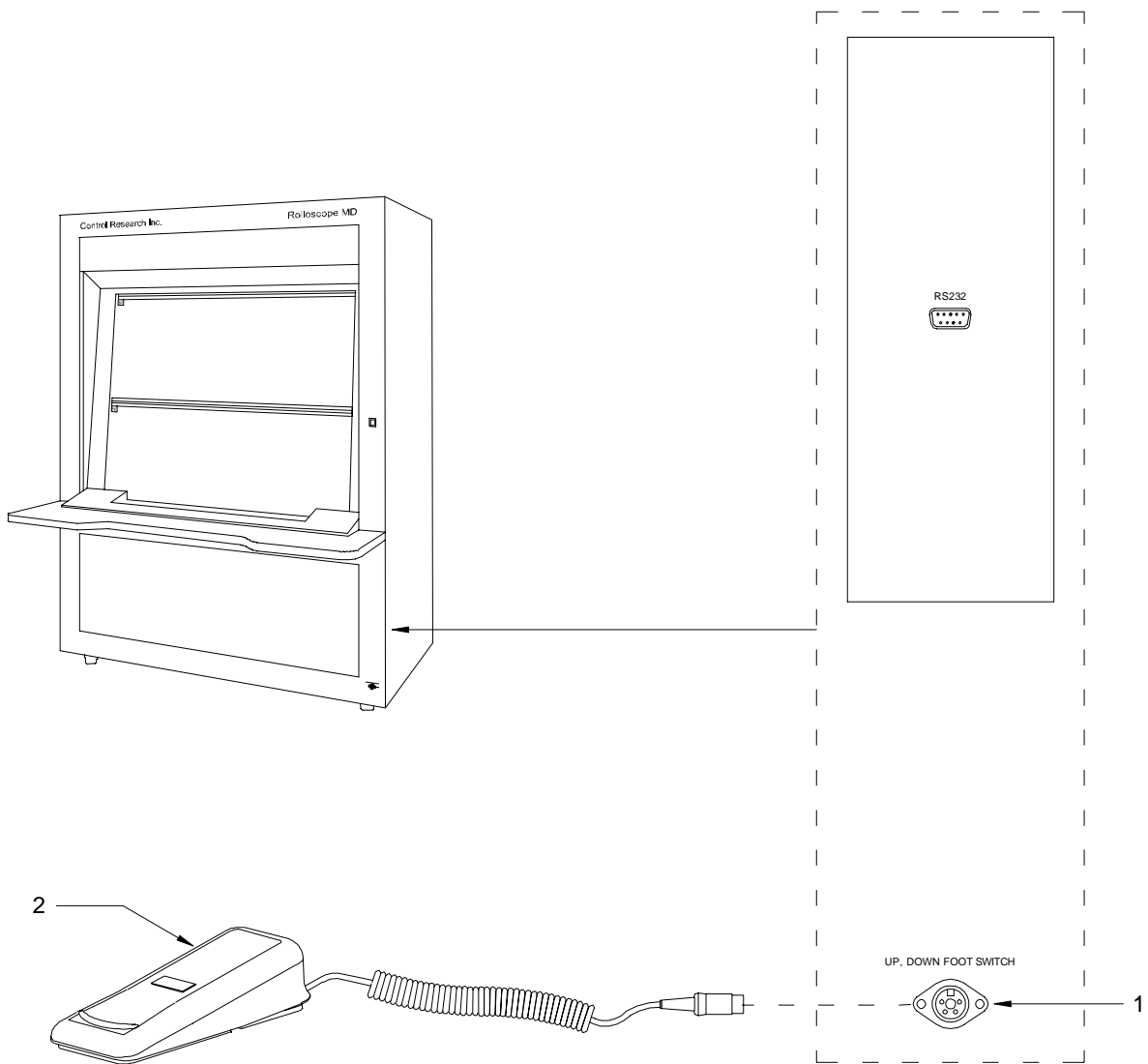

Figure 9-6-a

### 9.7 Transport Band Control Components

ITEM NO.	DESCRIPTION	QTY	PART NUMBER		COMMENTS
			MD	MP	
1	Magnetic Sensor	2	S-121-01-015	S-121-01-015	
2	Frequency/Voltage Converter	1	S-121-01-029	S-121-01-029	
3	Gear Tooth Sensor	1	S-121-01-028	S-121-01-028	
4	Photo Sensor Set	2	S-121-01-031	S-121-01-031	Includes both Emitter and Receiver
5	DC Gear Motor	1	S-121-01-027	S-121-01-027	
6	Anti-Static Brush	4*	S-121-27-002	S-121-27-002	* MP Quantity is 6

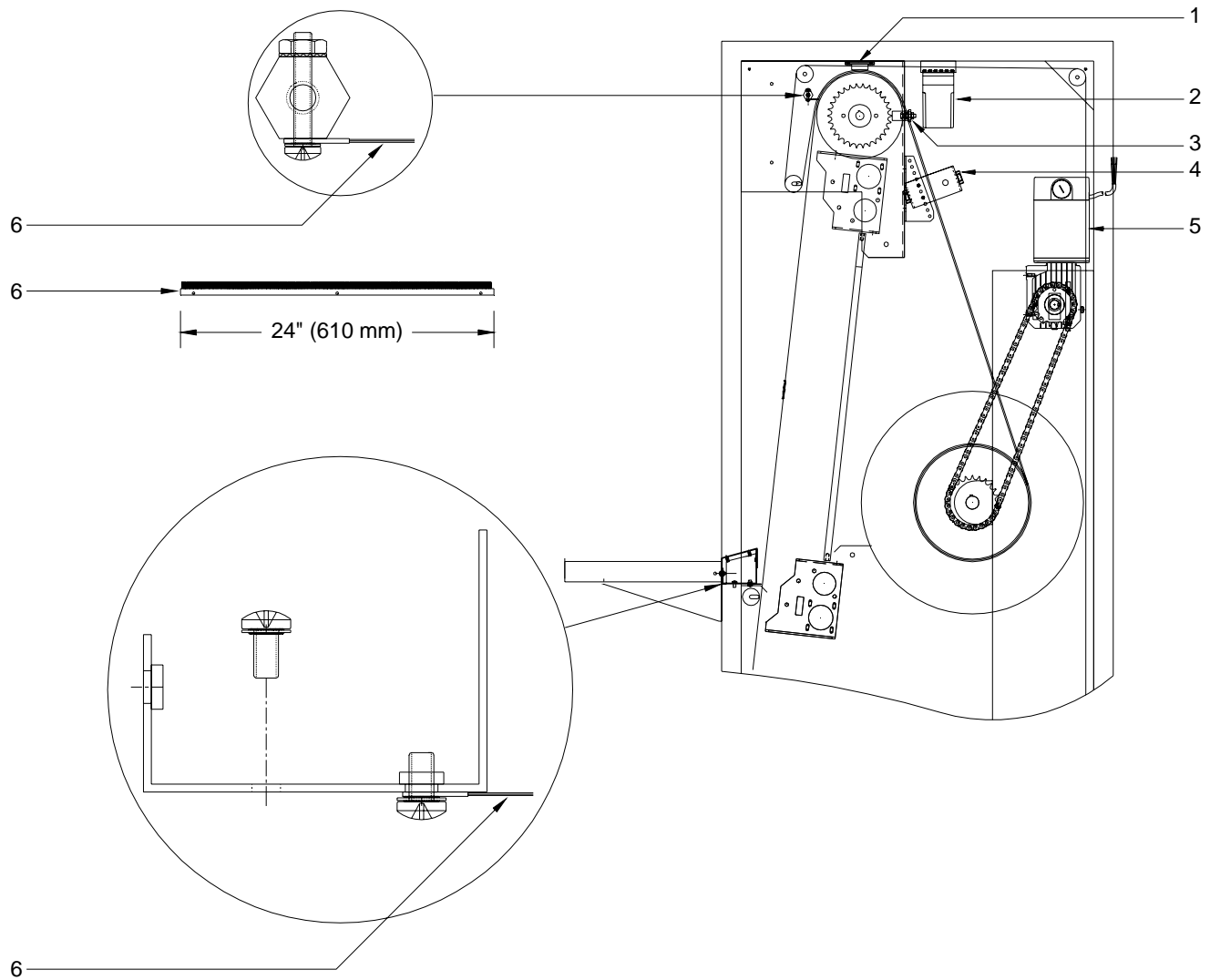

Figure 9-7-a

### 9.8 Transport Band Components

ITEM NO.	DESCRIPTION	QTY	PART NUMBER		COMMENTS
			MD	MP	
	Transport Band Assy. Complete	1	A-121-03-001	A-150-03-001	NOTE: For installation of this item, please contact Control Research, Inc.
1	Label 3/4" x 3/4", for Stop Point	95	S-121-03-007	S-121-03-007	
2a	String with Adhesive Tabs, white	86	S-121-03-016	S-150-03-016	
2b	String with Adhesive Tabs, clear	86	S-121-03-018	S-150-03-018	
3	Fasteners, Push-on, Nylon	1456*	S-121-03-003	S-121-03-003	* 1872 used in MP
4	Film Holding Clip	104	S-121-03-002	S-148-03-002	
5	Black Label for End Stops				Use 4 of Item 1
6	Steel Shim, 0.75 x 1 x 0.03"	6	S-121-03-008	S-121-03-008	Used for end stops by magnetic sensors
7	Label Set, Numbers 0 to 100	1	S-148-03-006	S-148-03-006	
8	Support, Backing Strip for Film Clip	104	S-121-03-004	S-148-03-004	

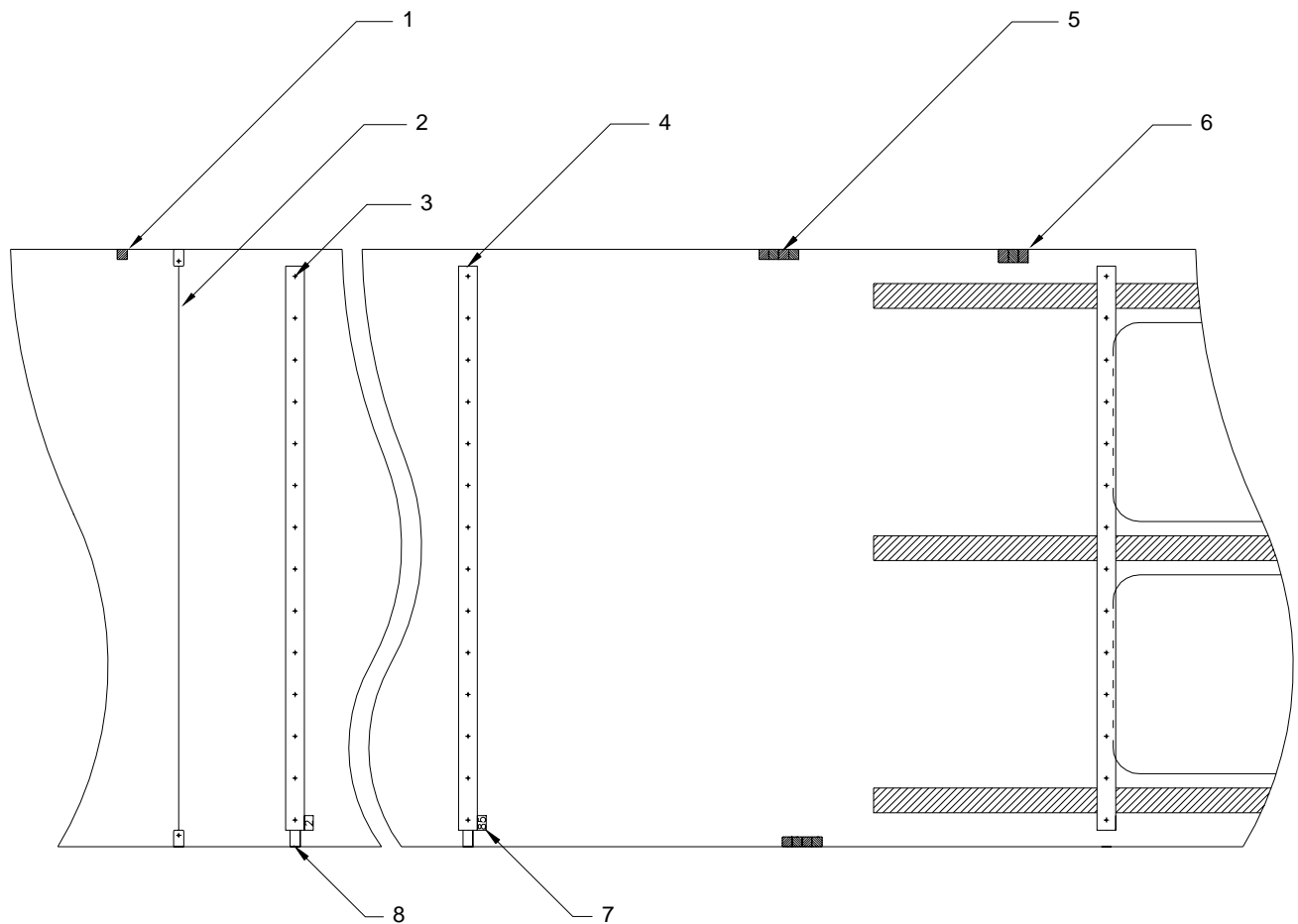

Figure 9-8-a

### 9.9 Shutter Drive Components

ITEM NO.	DESCRIPTION	QTY	PART NUMBER		COMMENTS
			MD	MP	
1	Step Motor, Left-Right Shutter	2	S-121-02-027	S-121-02-027	
2	Step Motor, Upper-lower Shutter	2	S-121-02-026	S-121-02-026	
3	Pulley, 10 Teeth, 1/4" Bore	4	S-121-02-042	S-121-02-042	
4	Belt, closed , XL110 (55 teeth)	4	S-121-02-033	S-121-02-033	
5	Belt, open, XL, steel reinforced	8	S-121-02-032	S-121-02-032	Specify Length

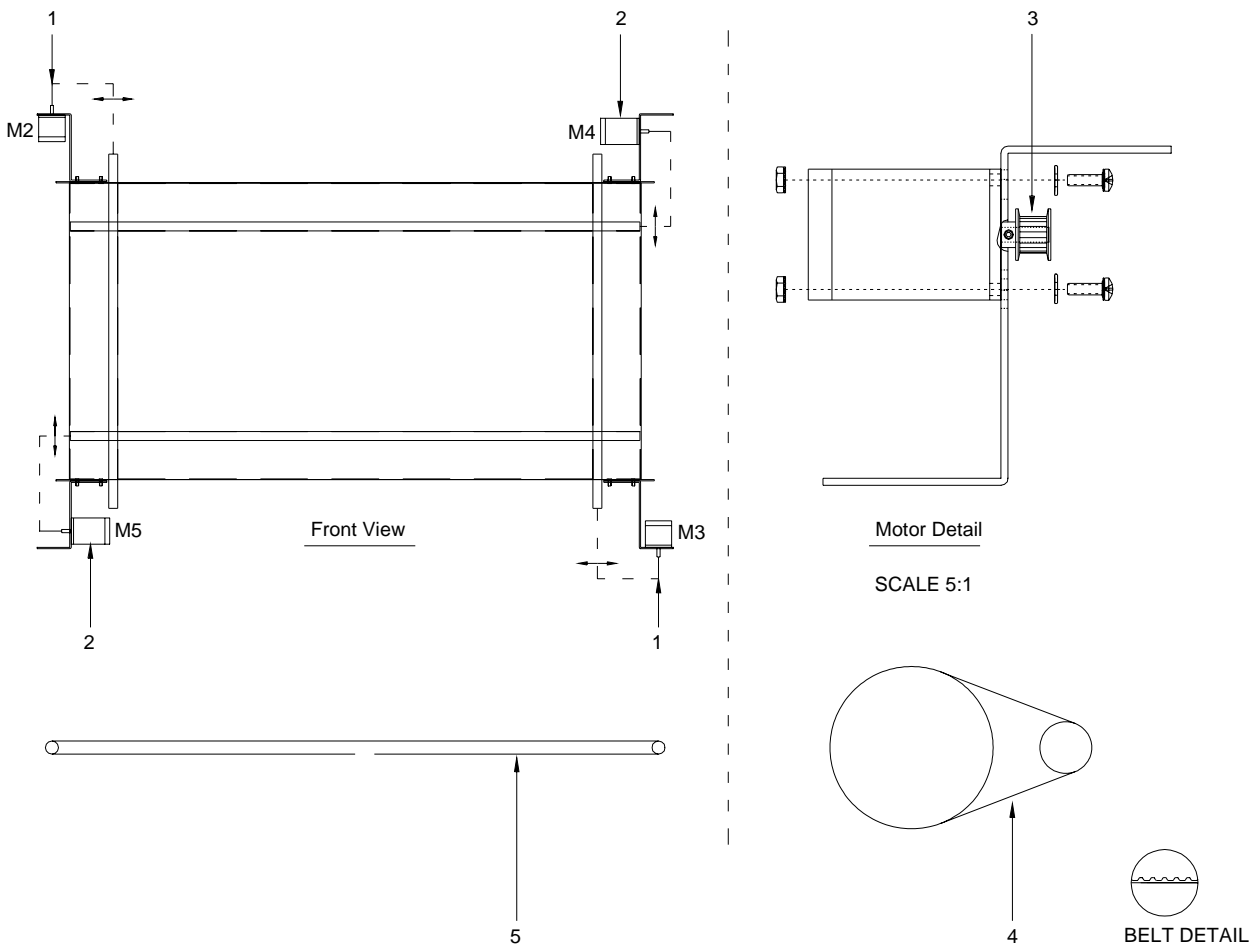

Figure 9-9-a

### 9.10 Line Connection Components

ITEM NO.	DESCRIPTION	QTY	PART NUMBER		COMMENTS
			MD	MP	
1a	Plug, 120 V, 15 A Hospital Grade, Right Angle	1	S-121-01-035	S-121-01-035	Used where line voltage is 120 V
1b	Plug, 220 V	1	S-121-01-049	S-121-01-049	Used where line voltage is 220 V
2	Line Cord, 3 x 16 AWG, 14.5 ft	1	S-121-01-034	S-121-01-034	
3	Line Filter, 10 A	1	S-121-01-307	S-121-01-307	
4a	Switch, Power, 220 V	1	S-121-01-308	S-121-01-308	Used where line voltage is 220 V
4b	Switch, Power, 120 V	1	S-121-01-306	S-121-01-306	Used where line voltage is 120 V
5	Transformer T1, 120/240 V	1	S-121-01-002	S-121-01-002	

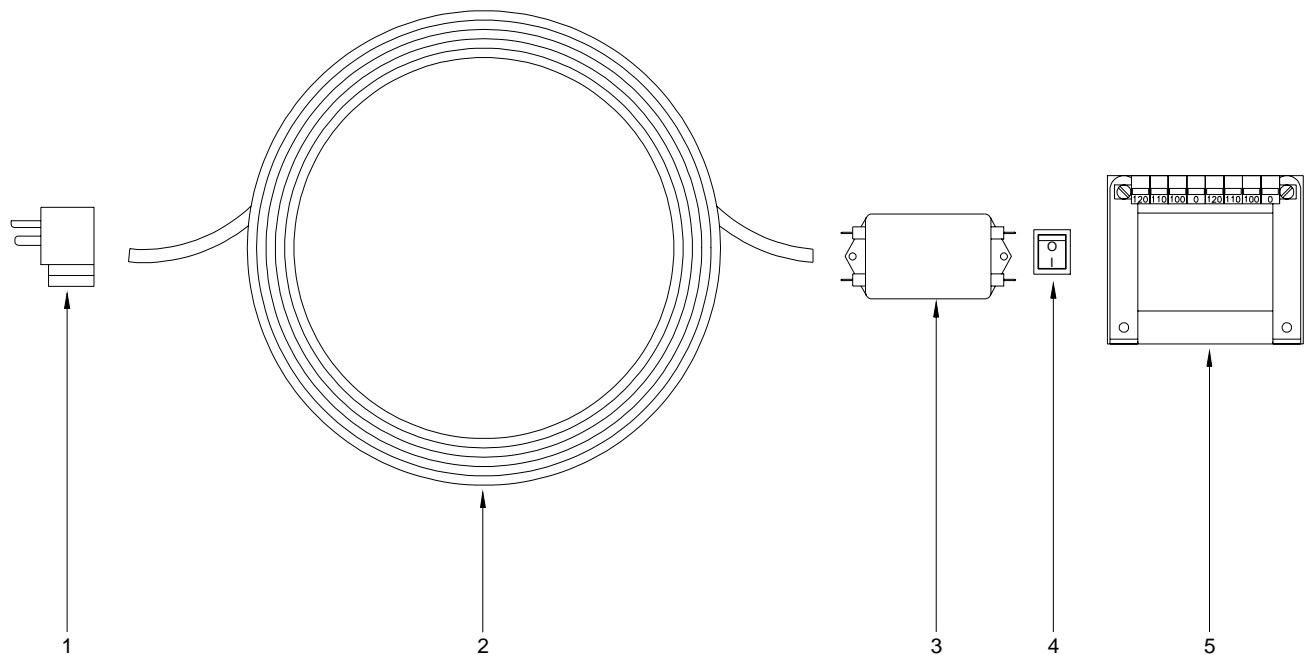

Figure 9-10-a

### 9.11 Bearings

ITEM NO.	DESCRIPTION	QTY	PART NUMBER		COMMENTS
			MD	MP	
1a	Bearing, Pillow Block, 2-13/64" C-C mount	4	S-121-01-016-a	S-121-01-016-a	Includes pillow block and bearing
1b	Bearing, Pillow Block 2" C-C mount	4	S-121-01-016-b	S-121-01-016-b	Includes pillow block and bearing
2	Bearing for Idler	4	S121-01-058	S-121-01-058	Includes a two-piece housing

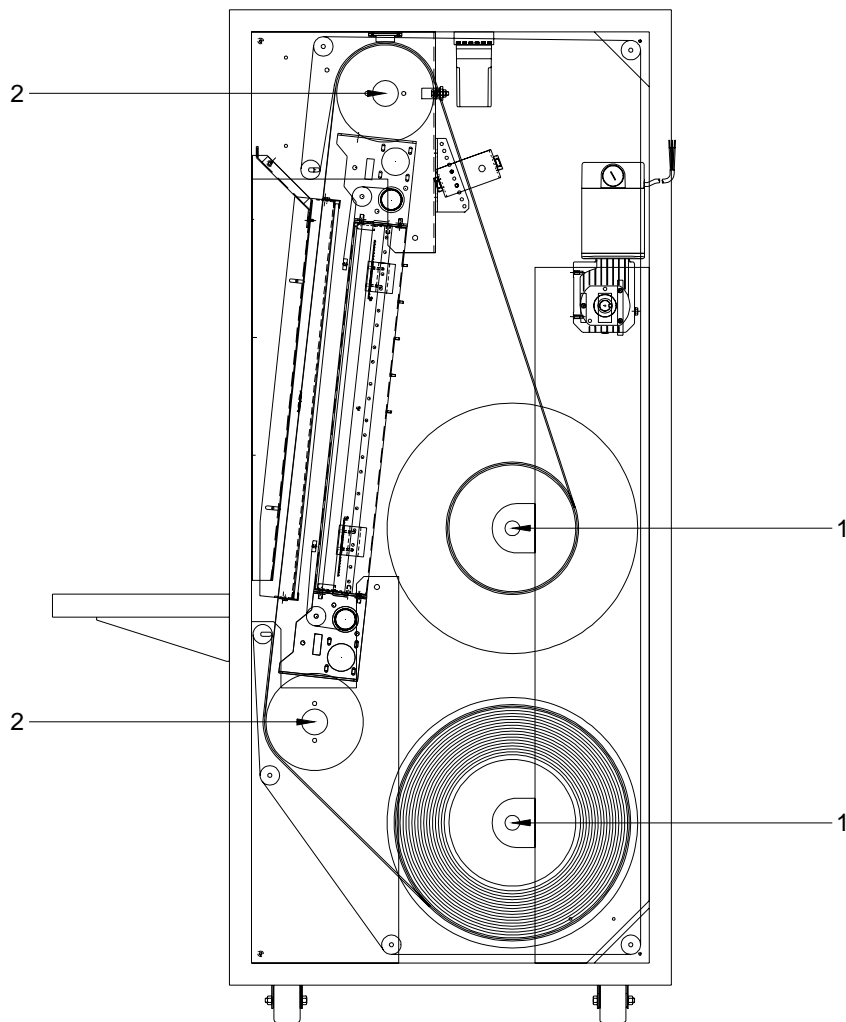

Figure 9-11-a